

**\*Reference Bill of Materials on Page 3**

\*Add Suffix WT for Matte White or BK for Matte Black

\*38° Swivel

This Document Contains Proprietary Data that is property of Pendant Systems which reserves all rights to it. Unauthorized use without authorization is prohibited.

**Pendant Systems**  
 1670 Winchester Rd.  
 Bensalem, PA 19020  
 P-215-638-8552  
 F-215-638-8554  
 www.PendantSystems.com

UNLESS OTHERWISE SPECIFIED DIMENSIONS ARE IN BOTH INCHES & MILLIMETERS UNLESS OTHERWISE NOTED TOLERANCES: LINEAR: XX= .02" XXX= $\pm .010"$ ANGULAR: $\pm 1$ Degree		FINISH:		TITLE: SK 3-8-OD SQ FL 36 5W	
DO NOT SCALE DRAWING		MATERIAL:		Part #	
DEBUR AND BREAK SHARP EDGES		DRAWN DATE: 7/7/17		SCALE: NTS	
Drawn By: MWR		SHEET 1 OF 3		REVISION	

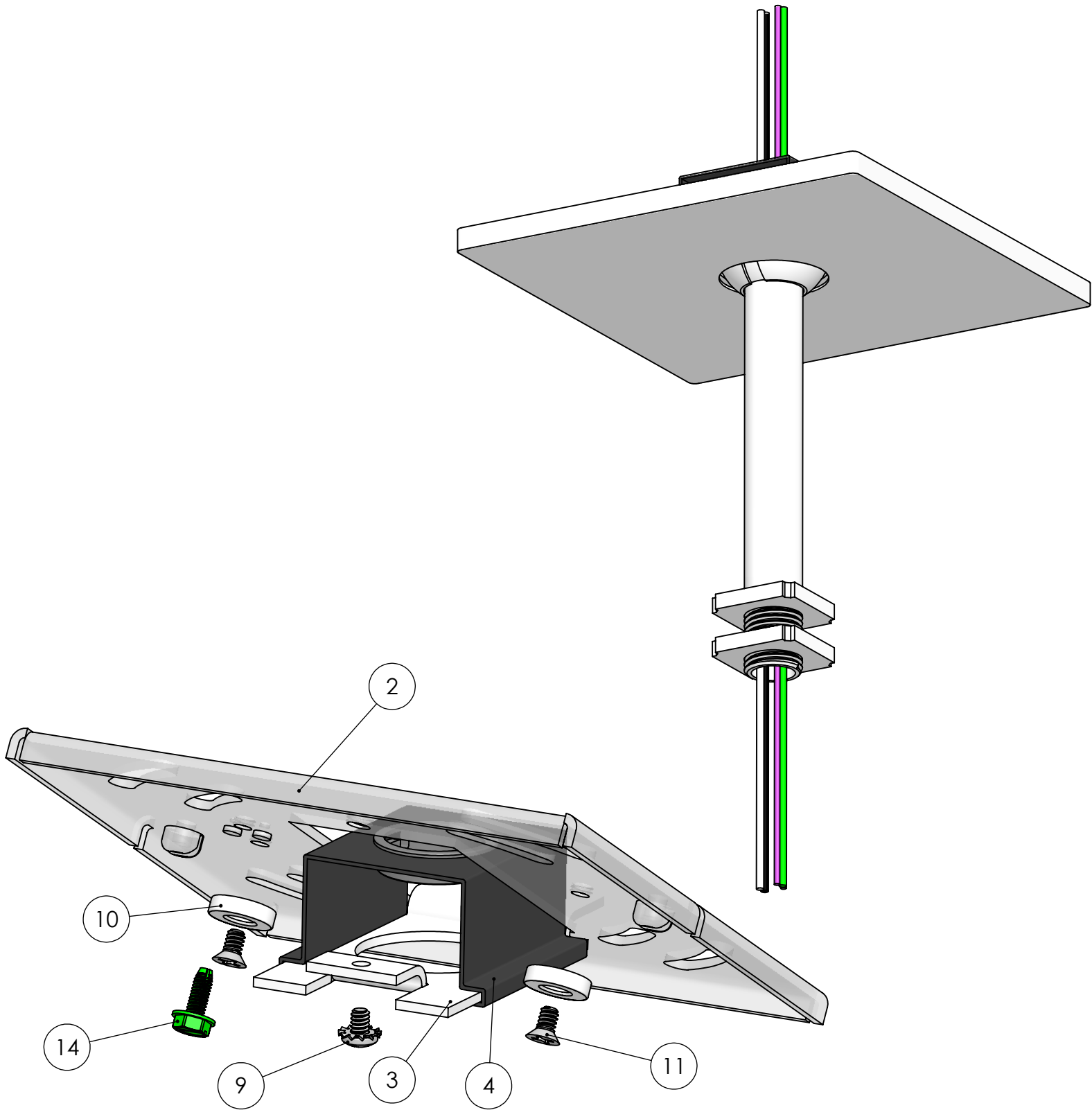

This Document  
Contains Proprietary  
Data that is property  
of Pendant Systems  
which reserves all  
rights to it.  
Unauthorized use  
without authorization  
is prohibited.

# Pendant Systems

1670 Winchester Rd.  
Bensalem, PA 19020  
P-215-638-8552  
F-215-638-8554  
[www.PendantSystems.com](http://www.PendantSystems.com)

UNLESS OTHERWISE SPECIFIED DIMENSIONS ARE IN BOTH INCHES & MILLIMETERS UNLESS OTHERWISE NOTED TOLERANCES:

LINEAR: XX= .02" XXX=  $\pm .010"$  ANGULAR:  $\pm 1$  Degree

FINISH:

TITLE:

SK 3-8-OD SQ FL 36 5W Assembled

DO NOT SCALE DRAWING

MATERIAL:

Part #

DEBUR AND BREAK SHARP EDGES

REVISION

DRAWN DATE: 7/7/17

Drawn By: MWR

SCALE: NTS

SHEET 2 OF 3

ITEM NO.	PART NUMBER	DESCRIPTION	QTY.
1	276B SQ	5" Canopy w/1.180" CH	1
2	MP Crossbar	Crossbar 14 Gauge Zinc Plated Steel 4.8" L x 4.8" W x .075" Material Thickness. GS inserted	1
3	MP Plate HB	Monopoint Plate for Half Ball for MP Crossbar 2.82" L x 1.650" W x .075" Material Thickness Half Ball Opening for #35, #34 and #147 Tapped 8/32" Hole Zinc Plated Steel	1
4	MP Swivel Clip	Mono Point Swivel Retaining Clip for MP- Plate HB Spring Steel	1
5	#237	.875" Hole Bushing .945" W x .750" I.D. x .250" H .063" Max Panel Thickness	1
6	#34ADJ	3/8" IP Slip Half Ball Bright Casting	1
7	#ADJ-SS	1/4" -20 Short (.350" Long) Socket Set Screw w/.125" DIA Point & 1/8" Allen Hex Head Pin for ADJ Series Half Balls	1
8	#SSS	1/4" -20 Socket Set Screw w/.125 DIA & 1/8" Allen Hex Head Pin for ADJ Series Half Balls	1
9	183	8/32" x 1/4" Philip Head Ext Sems Steel Zinc Screw	1
10	Magnet	#6 & #8 Magnet	2
11	271	6/32" x 1/4" L Flat Head Philips Machine Screw	2
12	#22	3/8" IP x 1 1/16" Square x .073" Thick Zinc Plated	2
13	36" Stem 3-8 IP PH	36" Stem 3/8" IP Thread on Bottom. Pin Hole on Top	1
14	#32	8/32 Green Ground Screw	1
15	18 AWG Single Conductor Wire	White, Black & Green. 42" L Coiled into Kit	3
16	22 AWG Single Conductor Wire	Purple & Gray. 42" L Coiled into Kit	2
17	72B Wire Nut	Ideal 72B	5
18	ADJ Tool Kit	Drill Bit 1/8" & Allen Wrench 1/8"	1

This Document  
Contains Proprietary  
Data that is property  
of Pendant Systems  
which reserves all  
rights to it.  
Unauthorized use  
without authorization  
is prohibited.

## Pendant Systems

1670 Winchester Rd.  
Bensalem, PA 19020  
P-215-638-8552  
F-215-638-8554  
[www.PendantSystems.com](http://www.PendantSystems.com)

UNLESS OTHERWISE SPECIFIED DIMENSIONS ARE IN BOTH INCHES &  
MILLIMETERS UNLESS OTHERWISE NOTED TOLERANCES:

LINEAR: XX= .02" XXX=  $\pm$ .010" ANGULAR:  $\pm$  1 Degree

FINISH:

TITLE:

Bill of Materials

DO NOT SCALE DRAWING

MATERIAL:

Part #

DEBUR AND BREAK SHARP EDGES

REVISION

DRAWN DATE: 7/7/17

Drawn By: MWR

SCALE: NTS

SHEET 3 OF 3