

***Reference Bill of Materials on Page 3**

*Add Suffix WT for Matte White or BK for Matte Black

*38° Swivel

This Document Contains Proprietary Data that is property of Pendant Systems which reserves all rights to it. Unauthorized use without authorization is prohibited.

Pendant Systems

1670 Winchester Rd.
 Bensalem, PA 19020
 P-215-638-8552
 F-215-638-8554
 www.PendantSystems.com

UNLESS OTHERWISE SPECIFIED DIMENSIONS ARE IN BOTH INCHES & MILLIMETERS UNLESS OTHERWISE NOTED TOLERANCES:

LINEAR: XX= .02" XXX= \pm .010" ANGULAR: \pm 1 Degree

FINISH:

TITLE:

SK 3-8-OD RD FL 36 3W

DO NOT SCALE DRAWING

MATERIAL:

Part #

DEBUR AND BREAK SHARP EDGES

REVISION

DRAWN DATE: 6/21/17

Drawn By: MWR

SCALE: NTS

SHEET 1 OF 3

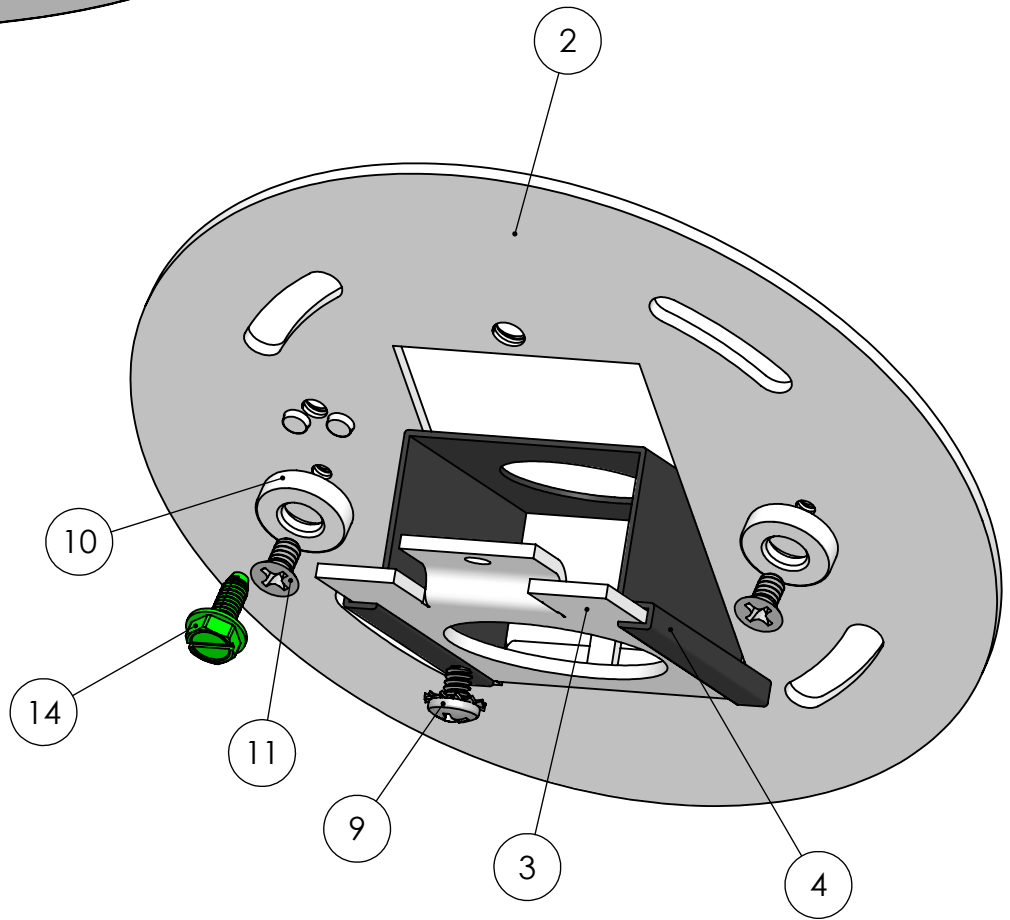
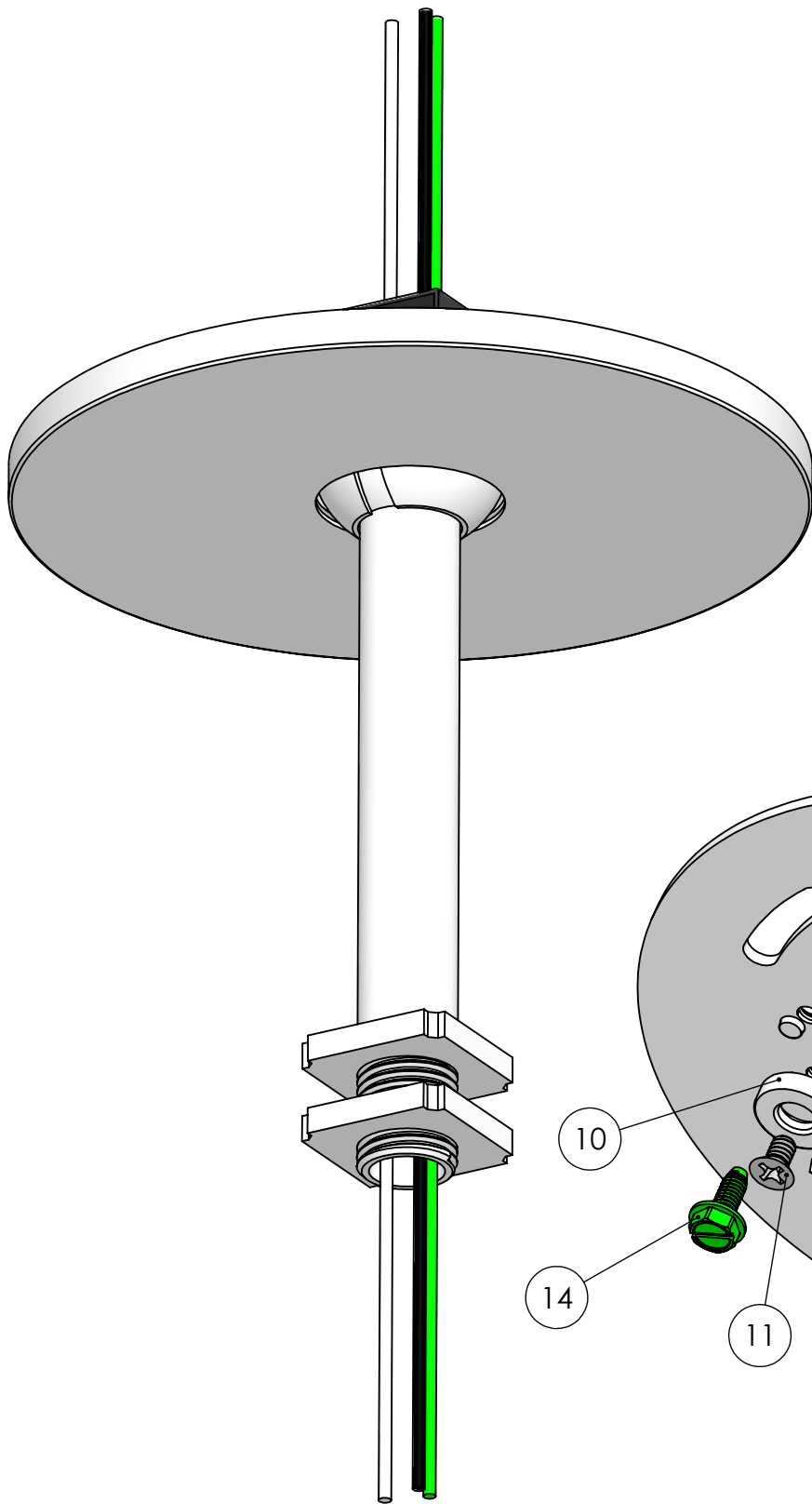

This Document
Contains Proprietary
Data that is property
of Pendant Systems
which reserves all
rights to it.
Unauthorized use
without authorization
is prohibited.

Pendant Systems

1670 Winchester Rd.
Bensalem, PA 19020
P-215-638-8552
F-215-638-8554
www.PendantSystems.com

UNLESS OTHERWISE SPECIFIED DIMENSIONS ARE IN BOTH INCHES & MILLIMETERS UNLESS OTHERWISE NOTED TOLERANCES:

LINEAR: XX= .02" XXX= $\pm .010"$ ANGULAR: ± 1 Degree

DO NOT SCALE DRAWING

DEBUR AND BREAK SHARP EDGES

DRAWN DATE: 6/21/17

FINISH:

MATERIAL:

Drawn By: MWR

TITLE:

SK 3-8-OD RD FL 36 3W Assembled

Part #

SCALE: NTS

SHEET 2 OF 3

REVISION

| ITEM NO. | PART NUMBER | DESCRIPTION | QTY. |
|----------|------------------------------|--|------|
| 1 | 276 | 5" Round w/ 1.18" CH | 1 |
| 2 | MP Crossbar Round | 4.75" Round Crossbar .080" Material Thickness Zinc Plated Steel | 1 |
| 3 | MP Plate HB | Monopoint Plate for Half Ball for MP Crossbar 2.82" L x 1.650" W x .075" Material Thickness Half Ball Opening for #35,#34 and #147 Tapped 8/32" Hole Zinc Plated Steel | 1 |
| 4 | MP Swivel Clip | Mono Point Swivel Retaining Clip for MP-Plate HB Spring Steel | 1 |
| 5 | #237 | .875" Hole Bushing .945" W x .750" I.D. x .250" H .063" Max Panel Thickness | 1 |
| 6 | #34ADJ | 3/8" IP Slip Half Ball Bright Casting | 1 |
| 7 | #ADJ-SS | 1/4" -20 Short (.350" Long) Socket Set Screw w/.125" DIA Point & 1/8" Allen Hex Head Pin for ADJ Series Half Balls | 1 |
| 8 | #SSS | 1/4" -20 Socket Set Screw w/.125 DIA & 1/8" Allen Hex Head Pin for ADJ Series Half Balls | 1 |
| 9 | 183 | 8/32" x 1/4" Philip Head Ext Sems Steel Zinc Screw | 1 |
| 10 | Magnet | #6 & #8 Magnet | 2 |
| 11 | 271 | 6/32" x 1/4" L Flat Head Philips Machine Screw | 2 |
| 12 | #22 | 3/8" IP x 1 1/16" Square x .073" Thick Zinc Plated | 2 |
| 13 | 36" Stem 3-8 IP PH | 36" Stem 3/8" IP Thread on Bottom. Pin Hole on Top | 1 |
| 14 | #32 | 8/32 Green Ground Screw | 1 |
| 15 | 18 AWG Single Conductor Wire | White, Black & Green. 42" L Coiled into Kit | 3 |
| 16 | ADJ Tool Kit | Drill Bit 1/8" & Allen Wrench 1/8" | 1 |
| 17 | 72B Wire Nut | Ideal 72B | 3 |

This Document Contains Proprietary Data that is property of Pendant Systems which reserves all rights to it. Unauthorized use without authorization is prohibited.

Pendant Systems

1670 Winchester Rd.
Bensalem, PA 19020
P-215-638-8552
F-215-638-8554
www.PendantSystems.com

UNLESS OTHERWISE SPECIFIED DIMENSIONS ARE IN BOTH INCHES & MILLIMETERS UNLESS OTHERWISE NOTED TOLERANCES:

LINEAR: XX= .02" XXX= \pm .010" ANGULAR: \pm 1 Degree

FINISH:

TITLE:

Bill of Materials

DO NOT SCALE DRAWING

MATERIAL:

Part #

DEBUR AND BREAK SHARP EDGES

REVISION

DRAWN DATE: 6/21/17

Drawn By: MWR

SCALE: NTS

SHEET 3 OF 3