

OPTIONS TABLE

Base Part #	Total Stem Length	Color
SK3/8-ID SQFL [XX]3W	36	Matte White (WT)
	72*	Matte Black (BK)
	108*	

*EX. **SK3/8-ID SQFL723WWT** -

- (1) 36" Stem 3/8" IP I.D.-I.D.
- (2) #49-1.5

*EX. **SK3/8-ID SQFL1083WBK** -

- (2) 36" Stem 3/8" IP I.D.-I.D.
- (3) #49-1.5

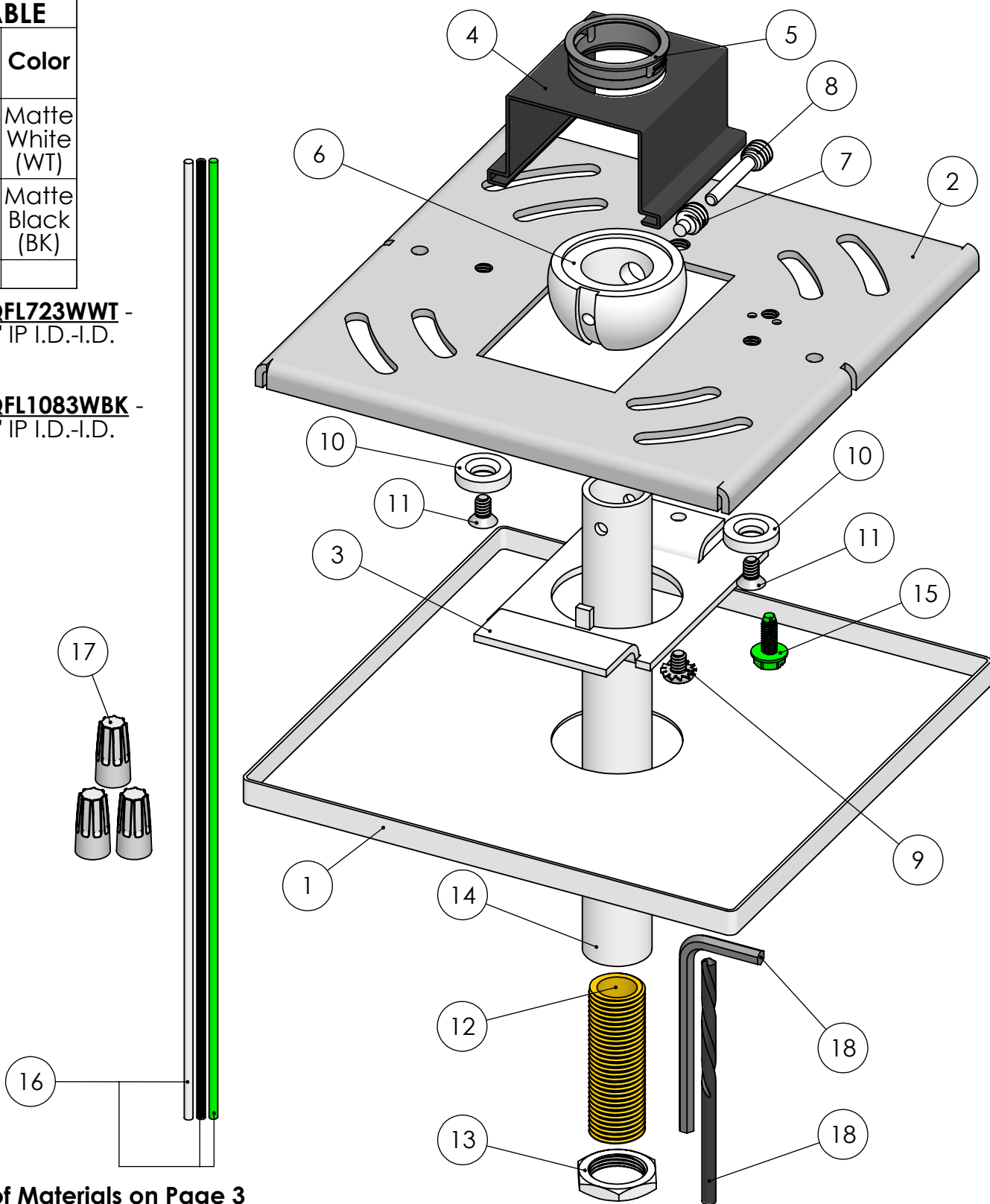

*Reference Bill of Materials on Page 3

*38° Swivel

This Document Contains Proprietary Data that is property of Pendant Systems which reserves all rights to it. Unauthorized use without authorization is prohibited.

Pendant Systems

1670 Winchester Rd.
Bensalem, PA 19020
P-215-638-8552
F-215-638-8554
www.PendantSystems.com

UNLESS OTHERWISE SPECIFIED DIMENSIONS ARE IN BOTH INCHES & MILLIMETERS UNLESS OTHERWISE NOTED TOLERANCES:

LINEAR: XX= .02" XXX= $\pm .010$ " ANGULAR: ± 1 Degree

FINISH:

TITLE:

SK 3-8-ID SQ FL [XX] 3W

DO NOT SCALE DRAWING

MATERIAL:

Part #

DEBUR AND BREAK SHARP EDGES

REVISION

DRAWN DATE: 7/5/17

Drawn By: MWR

SCALE: NTS

SHEET 1 OF 3

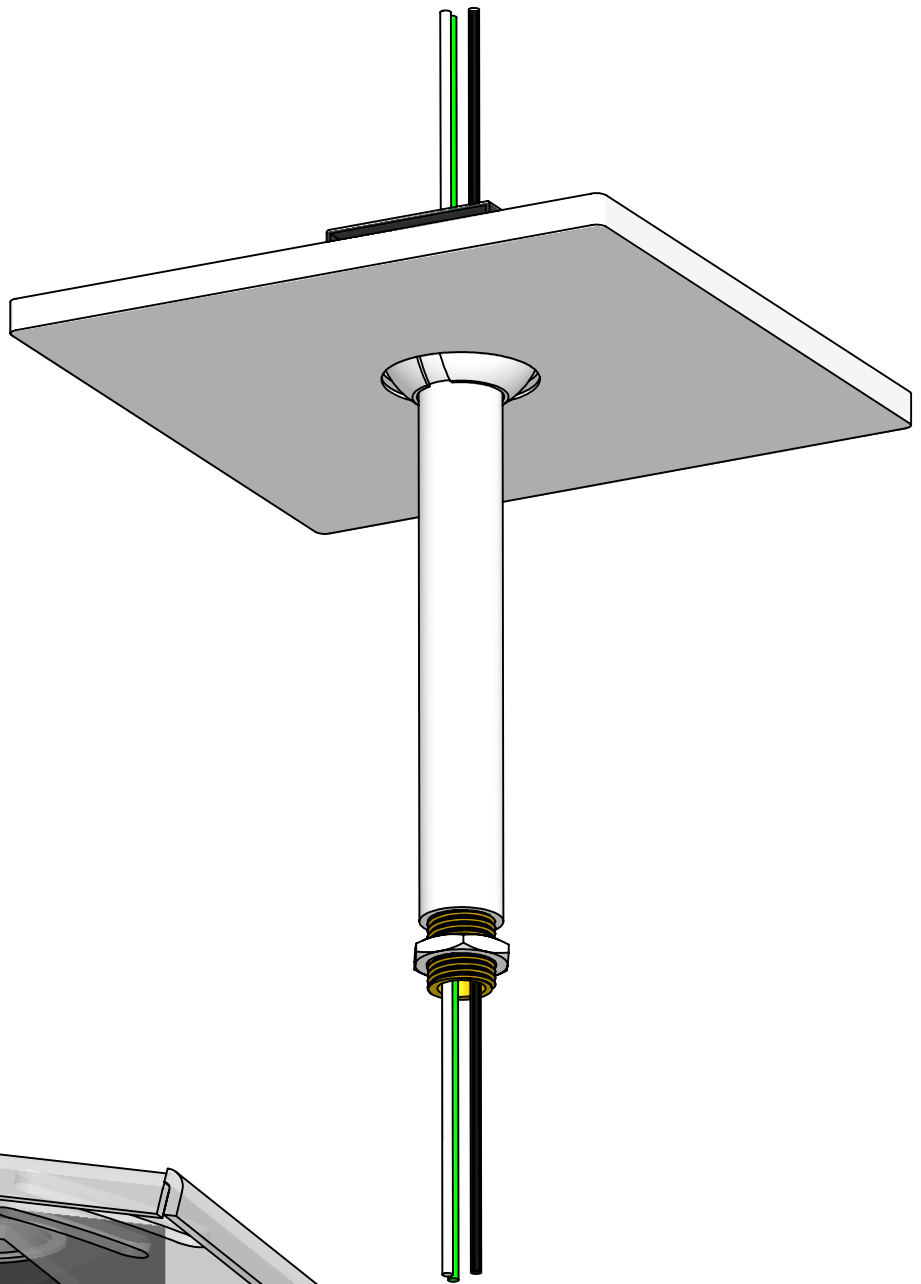

This Document
Contains Proprietary
Data that is property
of Pendant Systems
which reserves all
rights to it.
Unauthorized use
without authorization
is prohibited.

Pendant Systems

1670 Winchester Rd.
Bensalem, PA 19020
P-215-638-8552
F-215-638-8554
www.PendantSystems.com

UNLESS OTHERWISE SPECIFIED DIMENSIONS ARE IN BOTH INCHES & MILLIMETERS UNLESS OTHERWISE NOTED TOLERANCES:

LINEAR: XX= .02" XXX= $\pm .010"$ ANGULAR: ± 1 Degree

FINISH:

TITLE:

SK 3-8-ID SQ FL [XX] 3W Assembled

DO NOT SCALE DRAWING

MATERIAL:

Part #

DEBUR AND BREAK SHARP EDGES

REVISION

DRAWN DATE: 7/5/17

Drawn By: MWR

SCALE: NTS

SHEET 2 OF 3

ITEM NO.	PART NUMBER	DESCRIPTION	QTY.
1	276B SQ	5" Canopy w/1.180" CH	1
2	MP Crossbar	Crossbar 14 Gauge Zinc Plated Steel 4.8" L x 4.8" W x .075" Material Thickness. GS inserted	1
3	MP Plate HB	Monopoint Plate for Half Ball for MP Crossbar 2.82" L x 1.650" W x .075" Material Thickness Half Ball Opening for #35, #34 and #147 Tapped 8/32" Hole Zinc Plated Steel	1
4	MP Swivel Clip	Mono Point Swivel Retaining Clip for MP- Plate HB Spring Steel	1
5	#237	.875" Hole Bushing .945" W x .750" I.D. x .250" H .063" Max Panel Thickness	1
6	#34ADJ	3/8" IP Slip Half Ball Bright Casting	1
7	#ADJ-SS	1/4" -20 Short (.350" Long) Socket Set Screw w/.125" DIA Point & 1/8" Allen Hex Head Pin for ADJ Series Half Balls	1
8	#SSS	1/4" -20 Socket Set Screw w/.125 DIA & 1/8" Allen Hex Head Pin for ADJ Series Half Balls	1
9	183	8/32" x 1/4" Philip Head Ext Sems Steel Zinc Screw	1
10	Magnet	#6 & #8 Magnet	2
11	271	6/32" x 1/4" L Flat Head Philips Machine Screw	2
12	49-1.5	1/4" IP Nipple 1.5" L	[XX]
13	#25	1/4" IP x 11/16 O.D. x 1/8" Thick Zinc Plated	1
14	36" Stem 3-8IP I.D. PH	36" Stem 3/8" IP w-1/4" IP ID Thread on Bottom. Pin Hole on Top	1
15	#32	8/32 Green Ground Screw	1
16	18 AWG Single Conductor Wire	White, Black & Green. 42" L Coiled into Kit	3
17	72B Wire Nut	Ideal 72B	3
18	ADJ Tool Kit	Drill Bit 1/8" & Allen Wrench 1/8"	1

This Document
Contains Proprietary
Data that is property
of Pendant Systems
which reserves all
rights to it.
Unauthorized use
without authorization
is prohibited.

Pendant Systems

1670 Winchester Rd.
Bensalem, PA 19020
P-215-638-8552
F-215-638-8554
www.PendantSystems.com

UNLESS OTHERWISE SPECIFIED DIMENSIONS ARE IN BOTH INCHES &
MILLIMETERS UNLESS OTHERWISE NOTED TOLERANCES:

LINEAR: XX= .02" XXX= \pm .010" ANGULAR: \pm 1 Degree

FINISH:

TITLE:

Bill of Materials

DO NOT SCALE DRAWING

MATERIAL:

Part #

DEBUR AND BREAK SHARP EDGES

REVISION

DRAWN DATE: 7/5/17

Drawn By: MWR

SCALE: NTS

SHEET 3 OF 3