

OPTIONS TABLE		
Base Part #	Total Stem Length	Color
SK1/4-ID TR[XX]5W	36	Matte White (WT)
	72*	Matte Black (BK)
	108*	

*EX. SK1/4-ID TR725WWT -
 (1) 36" Stem 1/4" IP I.D.-I.D.
 (2) #60-1.5

*EX. SK1/4-ID TR1085WBK -
 (2) 36" Stem 1/4" IP I.D.-I.D.
 (3) #60-1.5

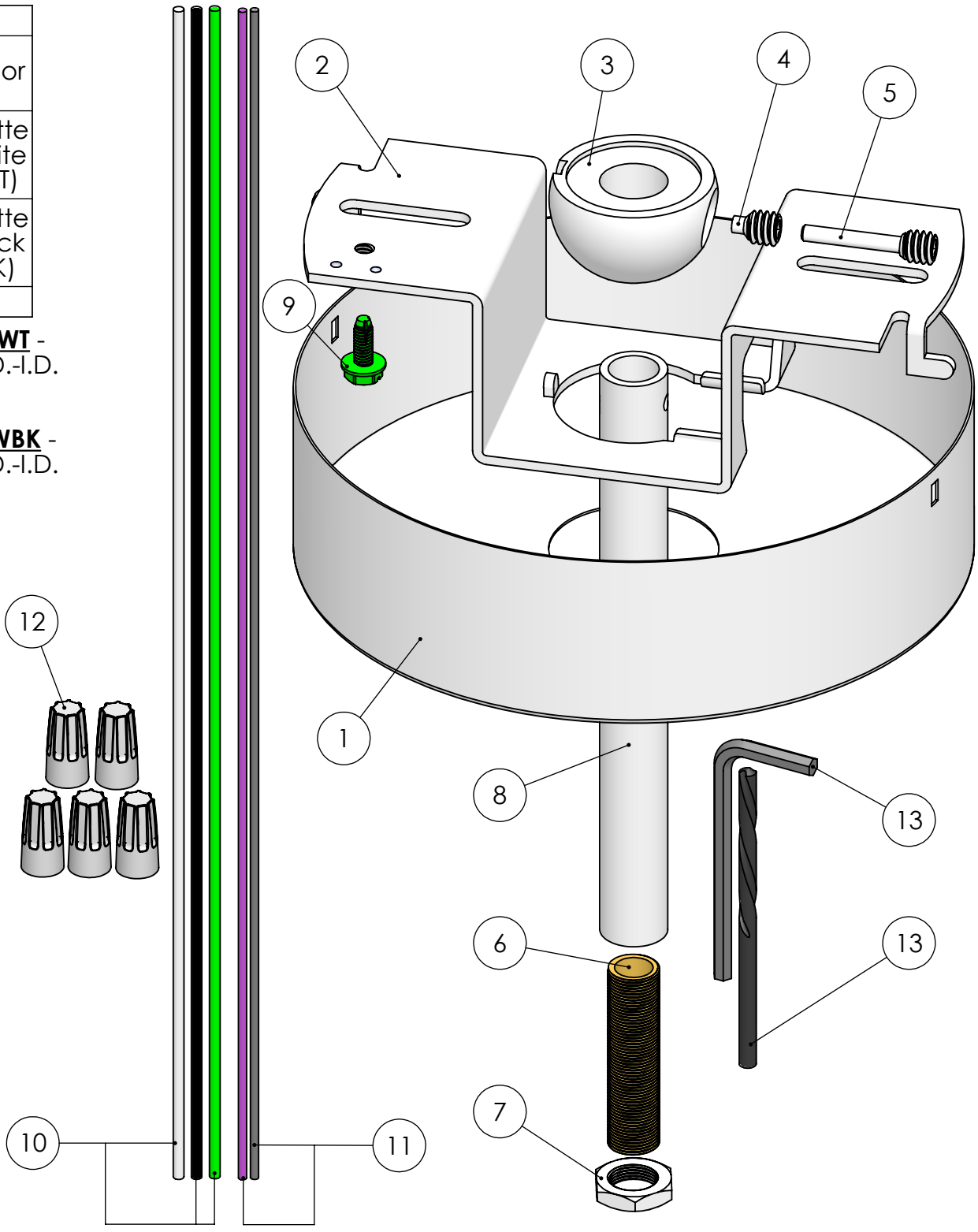

*Reference Bill of Materials on Page 3

*45° Swivel		This Document Contains Proprietary Data that is property of Pendant Systems which reserves all rights to it. Unauthorized use without authorization is prohibited.	<h1>Pendant Systems</h1> 1670 Winchester Rd. Bensalem, PA 19020 P-215-638-8552 F-215-638-8554 www.PendantSystems.com	
UNLESS OTHERWISE SPECIFIED DIMENSIONS ARE IN BOTH INCHES & MILLIMETERS UNLESS OTHERWISE NOTED TOLERANCES: LINEAR: XX= .02" XXX= ±.010" ANGULAR: ± 1 Degree				
DO NOT SCALE DRAWING	MATERIAL:	Part #	REVISION	
DEBUR AND BREAK SHARP EDGES		SCALE: NTS	SHEET 1 OF 3	
DRAWN DATE: 6/22/17	Drawn By: MWR			

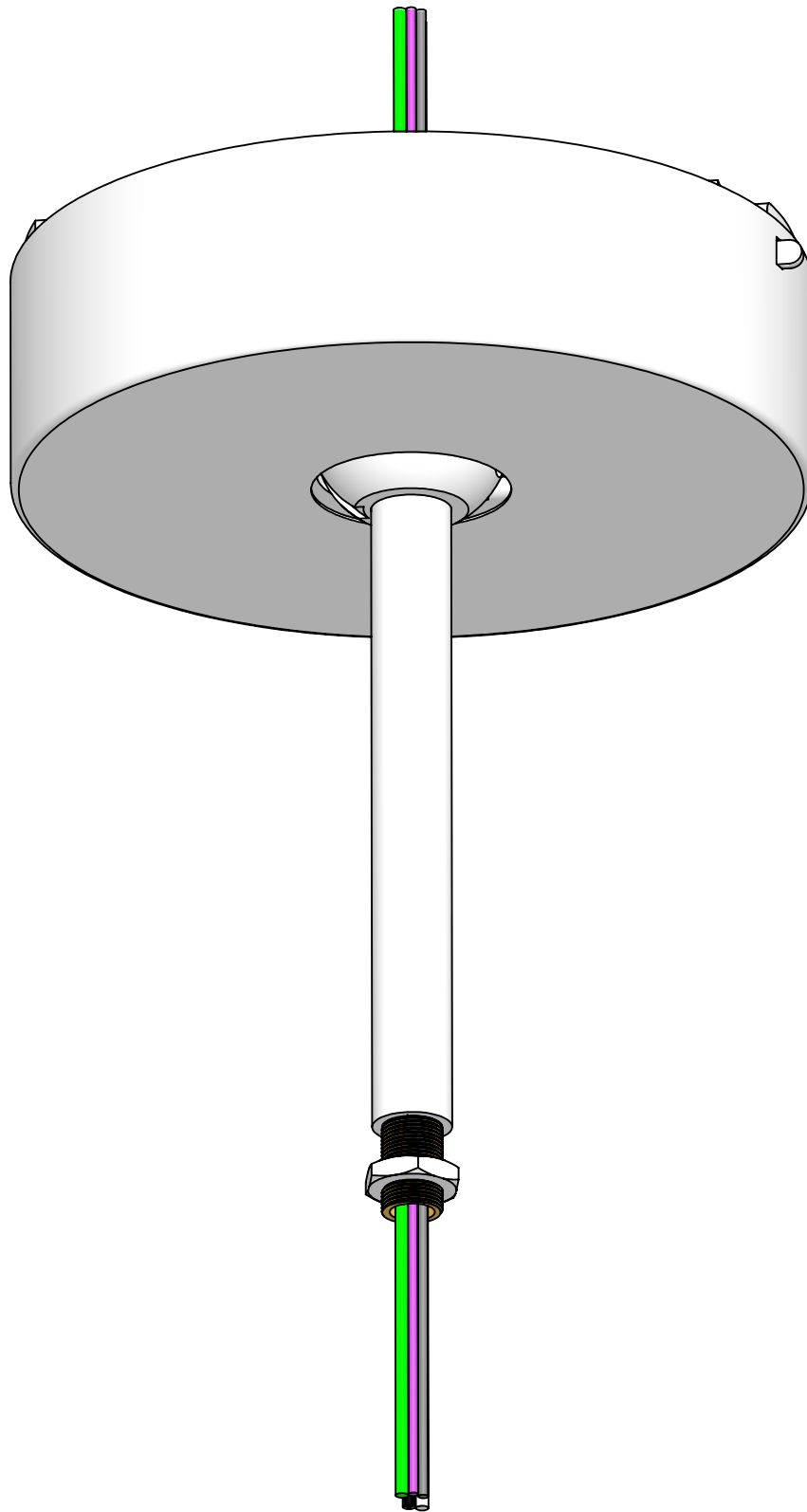

This Document
Contains Proprietary
Data that is property
of Pendant Systems
which reserves all
rights to it.
Unauthorized use
without authorization
is prohibited.

Pendant Systems

1670 Winchester Rd.
Bensalem, PA 19020
P-215-638-8552
F-215-638-8554
www.PendantSystems.com

UNLESS OTHERWISE SPECIFIED DIMENSIONS ARE IN BOTH INCHES & MILLIMETERS UNLESS OTHERWISE NOTED TOLERANCES: LINEAR: XX= .02" XXX= \pm .010" ANGULAR: \pm 1 Degree		FINISH:		TITLE: SK 1-4-ID TR [XX] 5W Assembled	
DO NOT SCALE DRAWING		MATERIAL:		Part #	
DEBUR AND BREAK SHARP EDGES				REVISION	
DRAWN DATE: 6/22/17		Drawn By: MWR		SCALE: NTS	
				SHEET 2 OF 3	

ITEM NO.	PART NUMBER	DESCRIPTION	QTY.
1	#46	5" DIA x 1.4" H White 1.25" Center Hole with side slots for #33	1
2	#33	Swivel Crossbar for #34, #35, #147, & #272 ADJ Half Balls. 2" W x 4 7/8" L x 1 3/8" H x 14 Gauge	1
3	#35ADJ	1/4" IP Slip Half Ball Bright Casting	1
4	#ADJ-SS	1/4" -20 Short (.350" Long) Socket Set Screw w/.125" DIA Point & 1/8" Allen Hex Head Pin for ADJ Series Half Balls	1
5	#SSS	1/4" -20 Socket Set Screw w/.125 DIA & 1/8" Allen Hex Head Pin for ADJ Series Half Balls	1
6	60-1.5	1/8" IP Nipple 1.5" L	[XX]
7	#133	1/8" IP x 9/16" O.D. x 1/8" Thick Zinc Plated	1
8	[XX] Stem 1-4IP I.D PH	36" Stem 1/4" IP W-1/8" ID Thread on Bottom. Pin Hole on Top	1
9	#32	8/32 Green Ground Screw	1
10	18 AWG Single Conductor Wire	White, Black & Green. 42" L Coiled into Kit	3
11	22 AWG Single Conductor Wire	Purple & Gray. 42" L Coiled into Kit	2
12	72B Wire Nut	Ideal 72B	5
13	ADJ Tool Kit	Drill Bit 1/8" & Allen Wrench 1/8"	1

This Document Contains Proprietary Data that is property of Pendant Systems which reserves all rights to it. Unauthorized use without authorization is prohibited.

Pendant Systems

1670 Winchester Rd.
 Bensalem, PA 19020
 P-215-638-8552
 F-215-638-8554
www.PendantSystems.com

UNLESS OTHERWISE SPECIFIED DIMENSIONS ARE IN BOTH INCHES & MILLIMETERS UNLESS OTHERWISE NOTED TOLERANCES:

LINEAR: XX= .02" XXX= \pm .010" ANGULAR: \pm 1 Degree

FINISH:

TITLE:

Bill of Materials

DO NOT SCALE DRAWING

MATERIAL:

Part #

DEBUR AND BREAK SHARP EDGES

REVISION

DRAWN DATE: 6/22/17

Drawn By: MWR

SCALE: NTS

SHEET 3 OF 3