

OPTIONS TABLE

| Base Part # | Total Stem Length | Color |
|-------------------|-------------------|------------------|
| SK1/4-ID TR[XX]3W | 36 | Matte White (WT) |
| | 72* | Matte Black (BK) |
| | 108* | |

*EX. **SK1/4-ID TR723WWT** -
 (1) 36" Stem 1/4" IP I.D.-I.D.
 (2) #60-1.5

*EX. **SK1/4-ID TR1083WBK** -
 (2) 36" Stem 1/4" IP I.D.-I.D.
 (3) #60-1.5

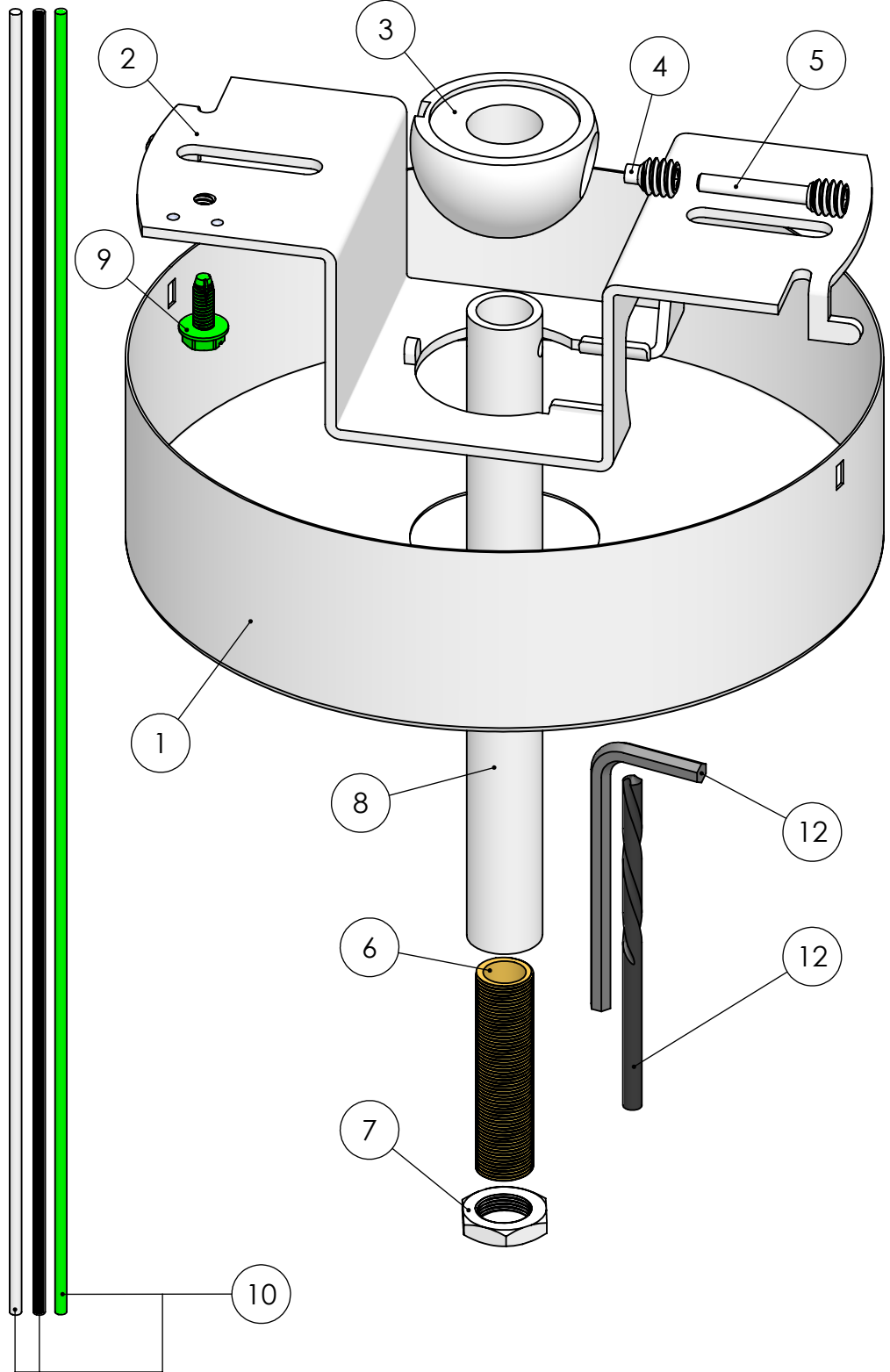
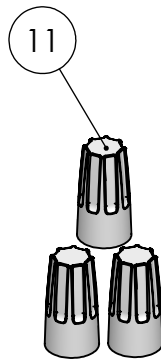

***Reference Bill of Materials on Page 3**

*45° Swivel

This Document Contains Proprietary Data that is property of Pendant Systems which reserves all rights to it. Unauthorized use without authorization is prohibited.

Pendant Systems
 1670 Winchester Rd.
 Bensalem, PA 19020
 P-215-638-8552
 F-215-638-8554
 www.PendantSystems.com

| | | | | | |
|--|--|---------------|--|--------------------------------|--|
| UNLESS OTHERWISE SPECIFIED DIMENSIONS ARE IN BOTH INCHES & MILLIMETERS UNLESS OTHERWISE NOTED TOLERANCES: LINEAR: XX= .02" XXX= $\pm .010"$ ANGULAR: ± 1 Degree | | FINISH: | | TITLE: SK 1-4-ID TR [XX] 3W | |
| DO NOT SCALE DRAWING | | MATERIAL: | | Part # | |
| DEBUR AND BREAK SHARP EDGES | | | | SCALE: NTS | |
| DRAWN DATE: 6/22/17 | | Drawn By: MWR | | SHEET 1 OF 3 | |
| | | | | REVISION | |

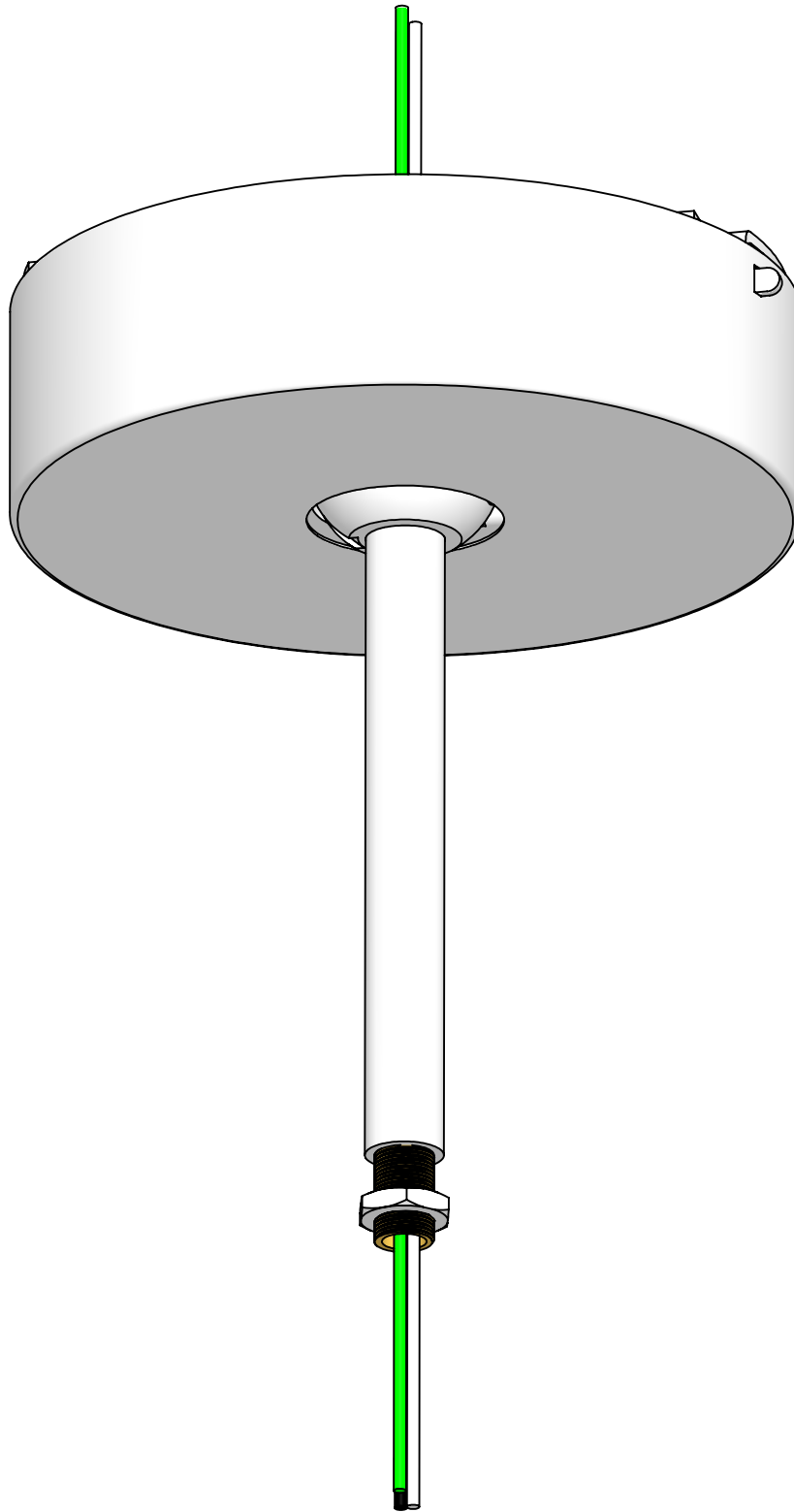

This Document
Contains Proprietary
Data that is property
of Pendant Systems
which reserves all
rights to it.
Unauthorized use
without authorization
is prohibited.

Pendant Systems

1670 Winchester Rd.
Bensalem, PA 19020
P-215-638-8552
F-215-638-8554
www.PendantSystems.com

UNLESS OTHERWISE SPECIFIED DIMENSIONS ARE IN BOTH INCHES &
MILLIMETERS UNLESS OTHERWISE NOTED TOLERANCES:

LINEAR: XX= .02" XXX= $\pm .010$ " ANGULAR: ± 1 Degree

FINISH:

TITLE:

SK 1-4-ID TR [XX] 3W Assembled

DO NOT SCALE DRAWING

MATERIAL:

Part #

DEBUR AND BREAK SHARP EDGES

REVISION

DRAWN DATE: 6/22/17

Drawn By: MWR

SCALE: NTS

SHEET 2 OF 3

| ITEM NO. | PART NUMBER | DESCRIPTION | QTY. |
|----------|------------------------------|--|------|
| 1 | #46 | 5" DIA x 1.4" H White 1.25" Center Hole with side slots for #33 | 1 |
| 2 | #33 | Swivel Crossbar for #34, #35, #147, & #272 ADJ Half Balls. 2" W x 4 7/8" L x 1 3/8" H x 14 Gauge | 1 |
| 3 | #35ADJ | 1/4" IP Slip Half Ball Bright Casting | 1 |
| 4 | #ADJ-SS | 1/4" -20 Short (.350" Long) Socket Set Screw w/.125" DIA Point & 1/8" Allen Hex Head Pin for ADJ Series Half Balls | 1 |
| 5 | #SSS | 1/4" -20 Socket Set Screw w/.125 DIA & 1/8" Allen Hex Head Pin for ADJ Series Half Balls | 1 |
| 6 | 60-1.5 | 1/8" IP Nipple 1.5" L | [XX] |
| 7 | #133 | 1/8" IP x 9/16" O.D. x 1/8" Thick Zinc Plated | 1 |
| 8 | [XX] Stem 1-4IP I.D PH | 36" Stem 1/4" IP w-1/8" IP ID Thread on Bottom. Pin Hole on Top | 1 |
| 9 | #32 | 8/32 Green Ground Screw | 1 |
| 10 | 18 AWG Single Conductor Wire | White, Black & Green. 42" L Coiled into Kit | 3 |
| 11 | 72B Wire Nut | Ideal 72B | 3 |
| 12 | ADJ Tool Kit | Drill Bit 1/8" & Allen Wrench 1/8" | 1 |

This Document Contains Proprietary Data that is property of Pendant Systems which reserves all rights to it. Unauthorized use without authorization is prohibited.

Pendant Systems

1670 Winchester Rd.
 Bensalem, PA 19020
 P-215-638-8552
 F-215-638-8554
www.PendantSystems.com

UNLESS OTHERWISE SPECIFIED DIMENSIONS ARE IN BOTH INCHES & MILLIMETERS UNLESS OTHERWISE NOTED TOLERANCES:

LINEAR: XX= .02" XXX= \pm .010" ANGULAR: \pm 1 Degree

FINISH:

TITLE:

Bill of Materials

DO NOT SCALE DRAWING

MATERIAL:

Part #

DEBUR AND BREAK SHARP EDGES

REVISION

DRAWN DATE: 6/22/17

Drawn By: MWR

SCALE: NTS

SHEET 3 OF 3