

***Reference Bill Of Materials on Page 3**

**STEM LENGTH WILL VARY. ORDER SEPARATELY
 MP15-[XX]-16 36PD SW1-2 USED WITH STEM
 1/2" IP
 1/2" IPS .800"-.810" O.D. 14 T.P.I.
 *42° SWIVEL**

This Document Contains Proprietary Data that is property of Pendant Systems which reserves all rights to it. Unauthorized use without authorization is prohibited.

Pendant Systems
 1670 Winchester Rd.
 Bensalem, PA 19020
 P-215-638-8552
 F-215-638-8554
 www.PendantSystems.com

UNLESS OTHERWISE SPECIFIED DIMENSIONS ARE IN BOTH INCHES & MILLIMETERS UNLESS OTHERWISE NOTED TOLERANCES: LINEAR: XX= .02" XXX= $\pm .010$ " ANGULAR: ± 1 Degree		FINISH:		TITLE: MP15-[XX]-16 36PD SW1-2	
DO NOT SCALE DRAWING		MATERIAL:		Part #	
DEBUR AND BREAK SHARP EDGES				SCALE: NTS	
DRAWN DATE: 7/13/16		Drawn By: MWR		SHEET 1 OF 3	
				REVISION	

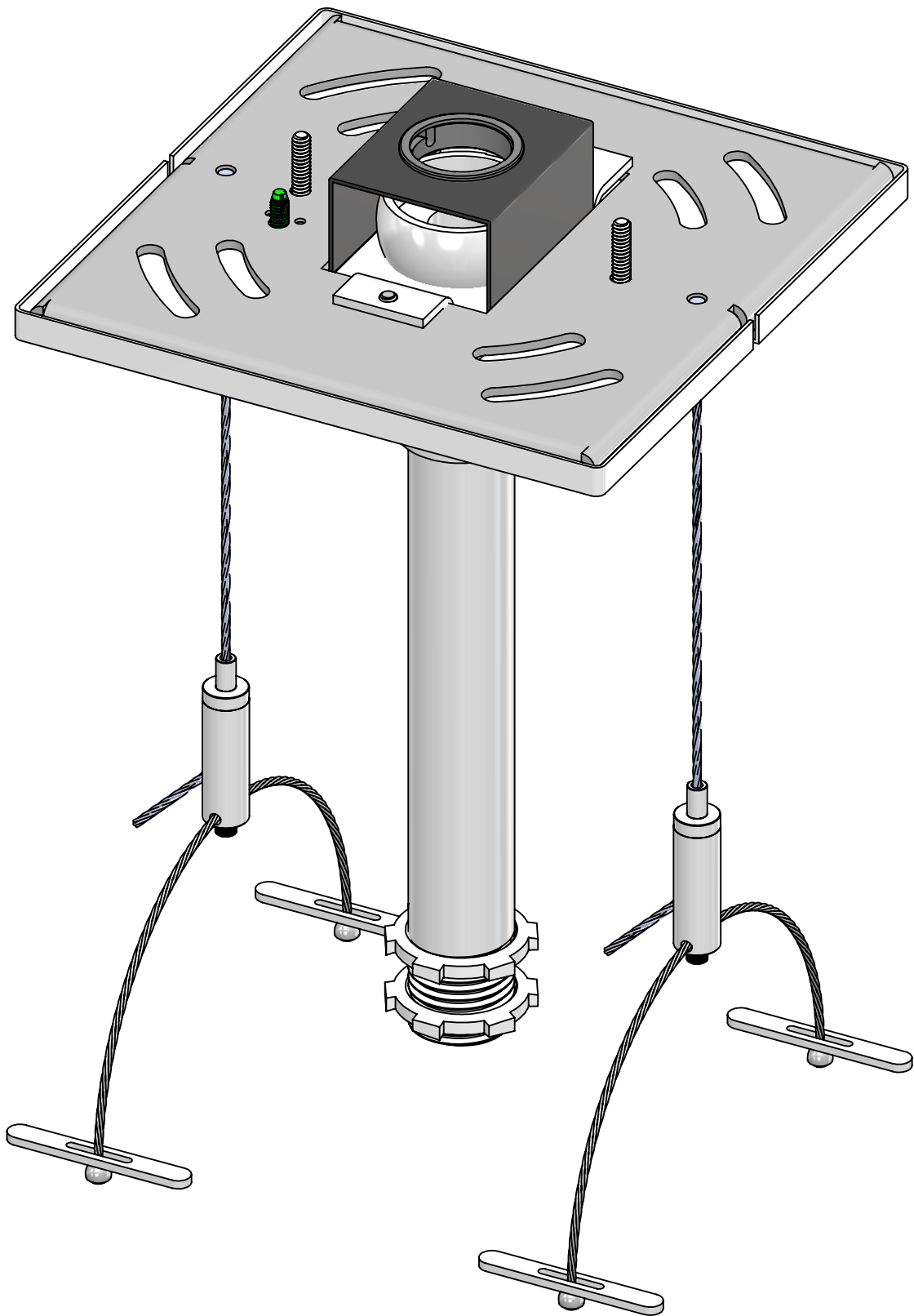

This Document
Contains Proprietary
Data that is property
of Pendant Systems
which reserves all
rights to it.
Unauthorized use
without authorization
is prohibited.

Pendant Systems

1670 Winchester Rd.
Bensalem, PA 19020
P-215-638-8552
F-215-638-8554
www.PendantSystems.com

UNLESS OTHERWISE SPECIFIED DIMENSIONS ARE IN INCHES & MILLIMETERS UNLESS OTHERWISE NOTED TOLERANCES:

LINEAR: XX= .02" XXX= $\pm .010$ " ANGULAR: ± 1 Degree

FINISH:

TITLE:

MP15-[XX]-16 36PD SW1-2 Assembled

DO NOT SCALE DRAWING

MATERIAL:

Part #

DEBUR AND BREAK SHARP EDGES

REVISION

DRAWN DATE: 7/13/16

Drawn By: MWR

SCALE:1:1

SHEET 2 OF 3

ITEM NO.	PART NUMBER	DESCRIPTION	QTY.
1	MP Crossbar	Crossbar 14 Gauge Zinc Plated Steel 4.8" L x 4.8" W x .075" Material Thickness. GS inserted	1
2	#32	8/32 Green Ground Screw	1
3	MP Screws	6/32" x 3/4" Long Zinc Plated Flat Countersunk Head Machine Screw. Available with White, Black or Zinc Finished Heads	2
4	AC1-16-[XX]G HB	1/16" Cable w/60" HB End 1/16" Galvanized Cable Fuse Cut with Die Cast #2 Half Ball Stop Available in 24", 36", 60", 120", 180", & 240" Lengths 7x7 Cable	2
5	243B SQ SL RM WHT	5" Flat Square Canopy W/1.25" CH, Slots & 2-RM 6/32 Holes	1
6	#77	1/2" IP Locknut Zinc Plated 1.14" O.D. x .125" H	2
7	183	8/32" x 1/4" Philip Head Ext Sems Steel Zinc Screw	1
8	MP Swivel Clip	Mono Point Swivel Retaining Clip for MP-Plate HB Spring Steel	1
9	#147	1/2" IP Tap Half Ball	1
10	MP Plate HB	Monopoint Plate for Half Ball for MP Crossbar 2.82" L x 1.650" W x .075" Material Thickness Half Ball Opening for #35, #34 and #147 Tapped 8/32" Hole Zinc Plated Steel	1
11	#237	.875" Hole Bushing .945" W x .750" I.D. x .250" H .063" Max Panel Thickness	1
12	MGR-SE-TH w/36CAB PD	Side Exit Gripper w/Through Hole for Crosscable for 1/16" Cable. Allen Set Screw on Bottom. 1.395" H x .354" W	2

This Document Contains Proprietary Data that is property of Pendant Systems which reserves all rights to it. Unauthorized use without authorization is prohibited.

Pendant Systems

1670 Winchester Rd.
Bensalem, PA 19020
P-215-638-8552
F-215-638-8554
www.PendantSystems.com

UNLESS OTHERWISE SPECIFIED DIMENSIONS ARE IN INCHES & MILLIMETERS UNLESS OTHERWISE NOTED TOLERANCES:

LINEAR: XX= .02" XXX= \pm .010" ANGULAR: \pm 1 Degree

FINISH:

TITLE:

DO NOT SCALE DRAWING

MATERIAL:

Part #

DEBUR AND BREAK SHARP EDGES

REVISION

DRAWN DATE: 7/13/16

Drawn By: MWR

SCALE: 1:1

SHEET 3 OF 3