

**\* Reference Bill Of Materials on Page 4**

STEM LENGTH WILL VARY. ORDER SEPARATELY  
 MP-SW3/8 EX ADJ USED WITH STEM 3/8" IP O.D. PH  
 3/8" IPS .625"-.635" O.D. 18 T.P.I.  
 Add Suffix WHT for White or BK for Black

**\*38° SWIVEL**

This Document  
 Contains Proprietary  
 Data that is property  
 of Pendant Systems  
 which reserves all  
 rights to it.  
 Unauthorized use  
 without authorization  
 is prohibited.

# Pendant Systems

1670 Winchester Rd.  
 Bensalem, PA 19020  
 P-215-638-8552  
 F-215-638-8554  
 www.PendantSystems.com

UNLESS OTHERWISE SPECIFIED DIMENSIONS ARE IN BOTH INCHES & MILLIMETERS UNLESS OTHERWISE NOTED TOLERANCES: LINEAR: XX= .02" XXX= $\pm .010$ " ANGULAR: $\pm 1$ Degree		FINISH:		TITLE:  MP-SW3/8 EX ADJ	
DO NOT SCALE DRAWING		MATERIAL:		Part #	
DEBUR AND BREAK SHARP EDGES				REVISION	
DRAWN DATE: 9/28/16		Drawn By: MWR		SCALE: NTS	
				SHEET 1 OF 4	

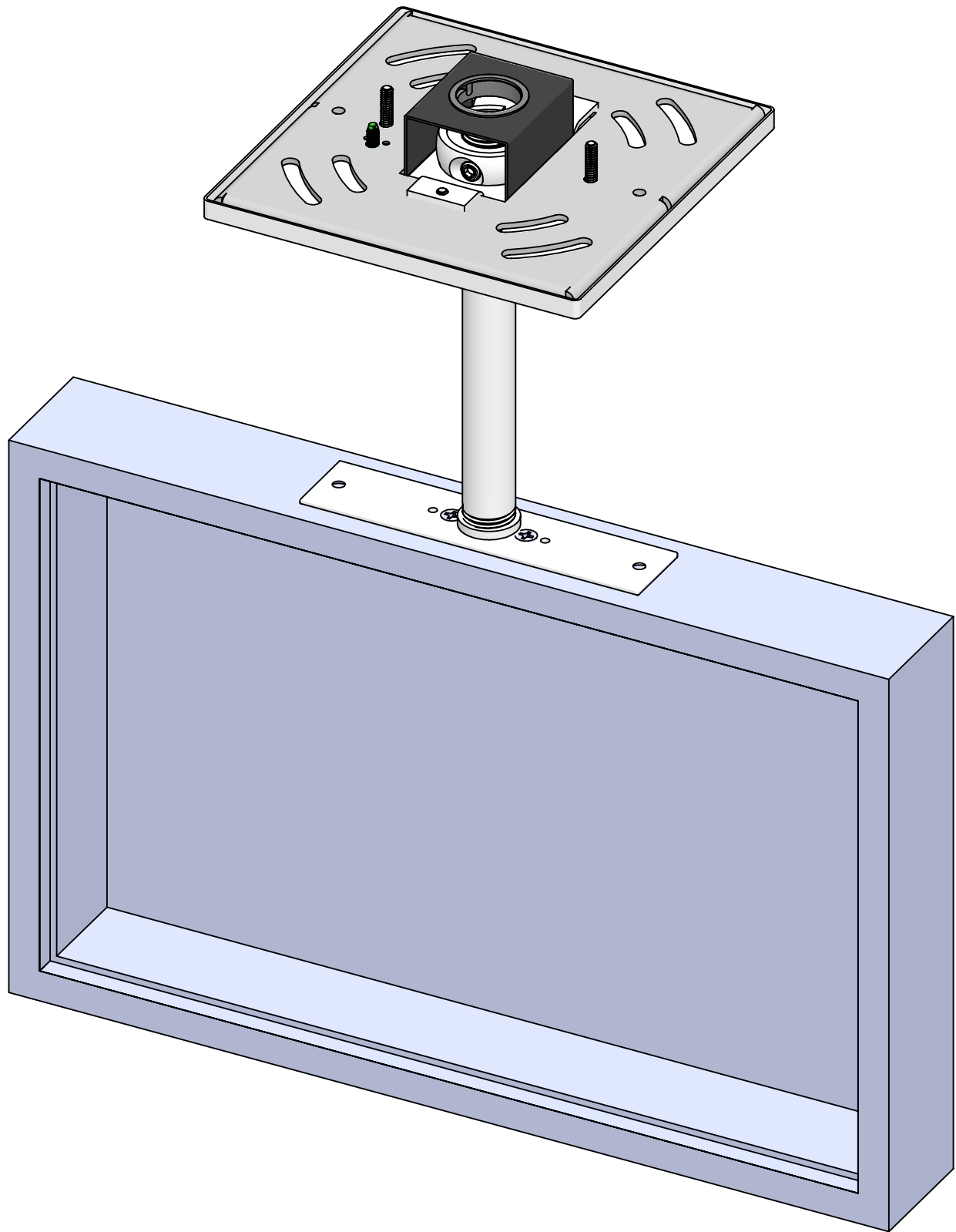

This Document  
Contains Proprietary  
Data that is property  
of Pendant Systems  
which reserves all  
rights to it.  
Unauthorized use  
without authorization  
is prohibited.

# Pendant Systems

1670 Winchester Rd.  
Bensalem, PA 19020  
P-215-638-8552  
F-215-638-8554  
[www.PendantSystems.com](http://www.PendantSystems.com)

UNLESS OTHERWISE SPECIFIED DIMENSIONS ARE IN BOTH INCHES & MILLIMETERS UNLESS OTHERWISE NOTED TOLERANCES:

LINEAR: XX= .02" XXX=  $\pm$ .010" ANGULAR:  $\pm$  1 Degree

FINISH:

TITLE:

MP-SW3/8 EX ADJ Assembled

DO NOT SCALE DRAWING

MATERIAL:

Part #

DEBUR AND BREAK SHARP EDGES

REVISION

DRAWN DATE: 9/28/16

Drawn By: MWR

SCALE: NTS

SHEET 2 OF 4

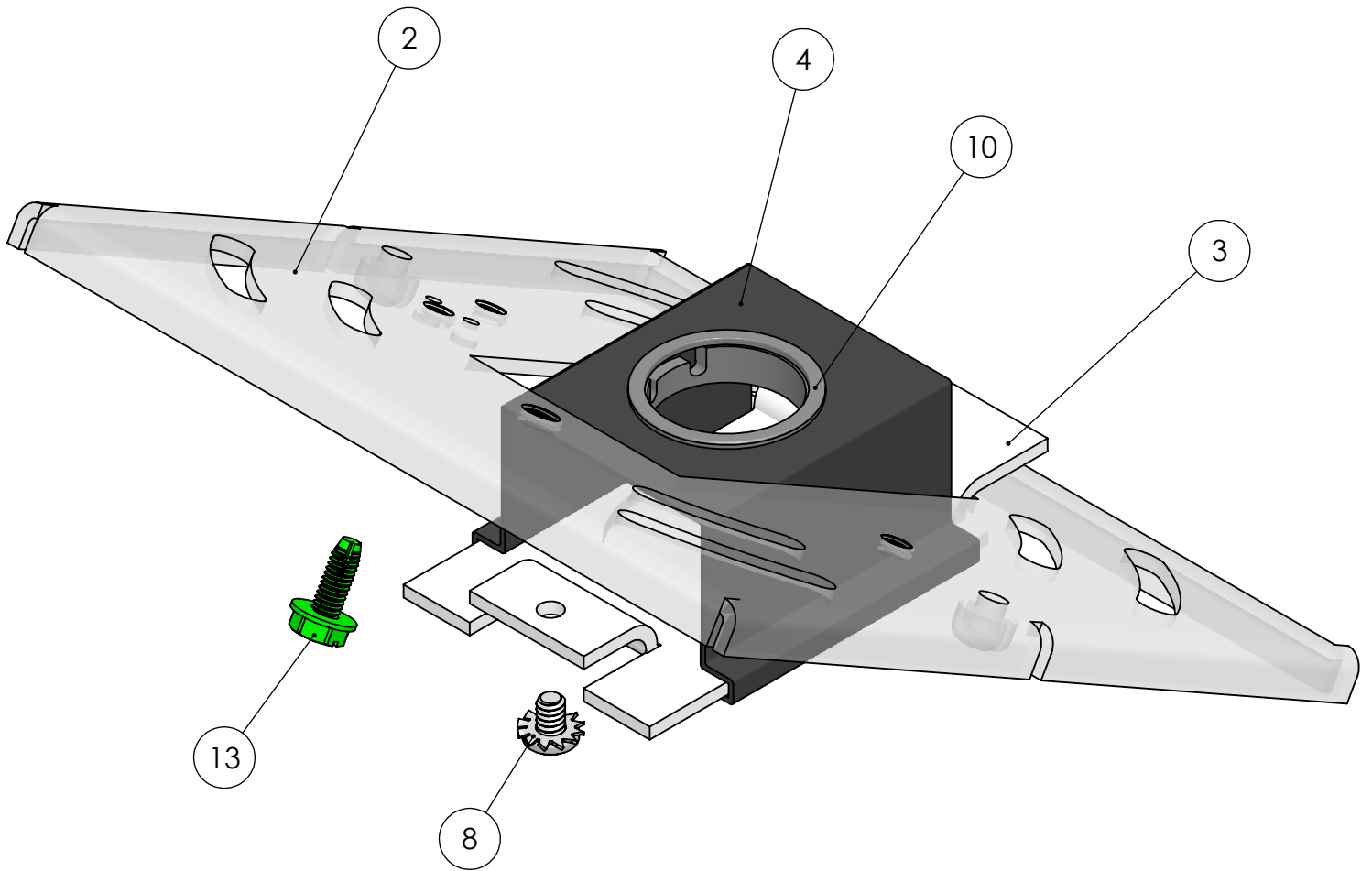

This Document  
Contains Proprietary  
Data that is property  
of Pendant Systems  
which reserves all  
rights to it.  
Unauthorized use  
without authorization  
is prohibited.

# Pendant Systems

1670 Winchester Rd.  
Bensalem, PA 19020  
P-215-638-8552  
F-215-638-8554  
[www.PendantSystems.com](http://www.PendantSystems.com)

UNLESS OTHERWISE SPECIFIED DIMENSIONS ARE IN BOTH INCHES & MILLIMETERS UNLESS OTHERWISE NOTED TOLERANCES:

LINEAR: XX= .02" XXX=  $\pm$ .010" ANGULAR:  $\pm$  1 Degree

FINISH:

MATERIAL:

TITLE: Monopoint Swivel Instruction

Part #

DO NOT SCALE DRAWING  
DEBUR AND BREAK SHARP EDGES

DRAWN DATE: 9/28/16

Drawn By: MWR

SCALE: NTS

SHEET 3 OF 4

REVISION

ITEM NO.	PART NUMBER	DESCRIPTION	QTY.
1	#243B SQ RM WHT	5" Flat Square Canopy W/1.25" CH & 2-RM 6/32 Holes	1
2	MP Crossbar	Crossbar 14 Gauge Zinc Plated Steel 4.8" L x 4.8" W x .075" Material Thickness. GS inserted	1
3	MP Plate HB	Monopoint Plate for Half Ball for MP Crossbar 2.82" L x 1.650" W x .075" Material Thickness Half Ball Opening for #35, #34 and #147 Tapped 8/32" Hole Zinc Plated Steel	1
4	MP Swivel Clip	Mono Point Swivel Retaining Clip for MP-Plate HB Spring Steel	1
5	#34ADJ	3/8" IP Slip Half Ball Bright Casting	1
6	#SSS	1/4" -20 Socket Set Screw w/.125 DIA & 1/8" Allen Hex Head Pin for ADJ Series Half Balls	1
7	#ADJ-SS	1/4" -20 Short (.350" Long) Socket Set Screw w/.125" DIA Point & 1/8" Allen Hex Head Pin for ADJ Series Half Balls	1
8	183	8/32" x 1/4" Philip Head Ext Sems Steel Zinc Screw	1
9	MP Screws	6/32" x 3/4" Long Zinc Plated Flat Countersunk Head Machine Screw. Available with White, Black or Zinc Finished Heads	2
10	#237	.875" Hole Bushing .945" W x .750" I.D. x .250" H .063" Max Panel Thickness	1
11	Exit Base	Exit Bracket Base 6/32" Slip & Tapped Holes. 2" x .875" Zinc Plated	1
12	Exit Bracket 3-8 IP	Exit Bracket with 3/8" IP tapped center hole & 6/32" tapped holes. 4.5" x .875" (Available in white, nickel and black)	1
13	#32	8/32 Green Ground Screw	1
14	Exit Bracket Screws	6/32" Screws	2

This Document Contains Proprietary Data that is property of Pendant Systems which reserves all rights to it. Unauthorized use without authorization is prohibited.

## Pendant Systems

1670 Winchester Rd.  
 Bensalem, PA 19020  
 P-215-638-8552  
 F-215-638-8554  
[www.PendantSystems.com](http://www.PendantSystems.com)

UNLESS OTHERWISE SPECIFIED DIMENSIONS ARE IN BOTH INCHES & MILLIMETERS UNLESS OTHERWISE NOTED TOLERANCES:

LINEAR: XX= .02" XXX=  $\pm .010"$  ANGULAR:  $\pm 1$  Degree

FINISH:

TITLE:

Bill of Materials

DO NOT SCALE DRAWING

MATERIAL:

Part #

DEBUR AND BREAK SHARP EDGES

REVISION

DRAWN DATE: 9/28/16

Drawn By: MWR

SCALE: NTS

SHEET 4 OF 4