

**\*Reference Bill of Materials on Page 3**

STEM LENGTH WILL VARY. ORDER SEPARATELY  
 MP-SW1/2 MAG USED WITH STEM 1/2" IP  
 1/2" IPS .800"-.810" O.D. 14 T.P.I

\*42° SWIVEL

This Document  
 Contains Proprietary  
 Data that is property  
 of Pendant Systems  
 which reserves all  
 rights to it.  
 Unauthorized use  
 without authorization  
 is prohibited.

# Pendant Systems

1670 Winchester Rd.  
 Bensalem, PA 19020  
 P-215-638-8552  
 F-215-638-8554  
 www.PendantSystems.com

UNLESS OTHERWISE SPECIFIED DIMENSIONS ARE IN BOTH INCHES & MILLIMETERS UNLESS OTHERWISE NOTED TOLERANCES: LINEAR: XX= .02" XXX= $\pm .010$ " ANGULAR: $\pm 1$ Degree		FINISH:		TITLE: <b>MP-SW1-2 MAG</b>	
DO NOT SCALE DRAWING		MATERIAL:		Part #	
DEBUR AND BREAK SHARP EDGES		Drawn By: <b>MWR</b>		SCALE: NTS	
DRAWN DATE: <b>2/13/17</b>				SHEET 1 OF 3	
				REVISION	

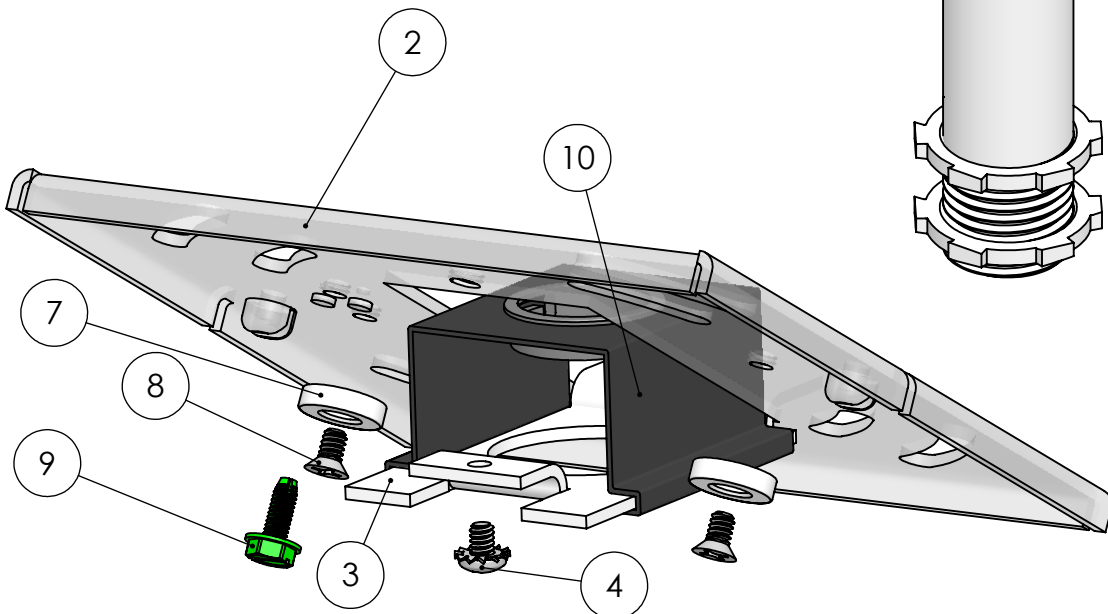
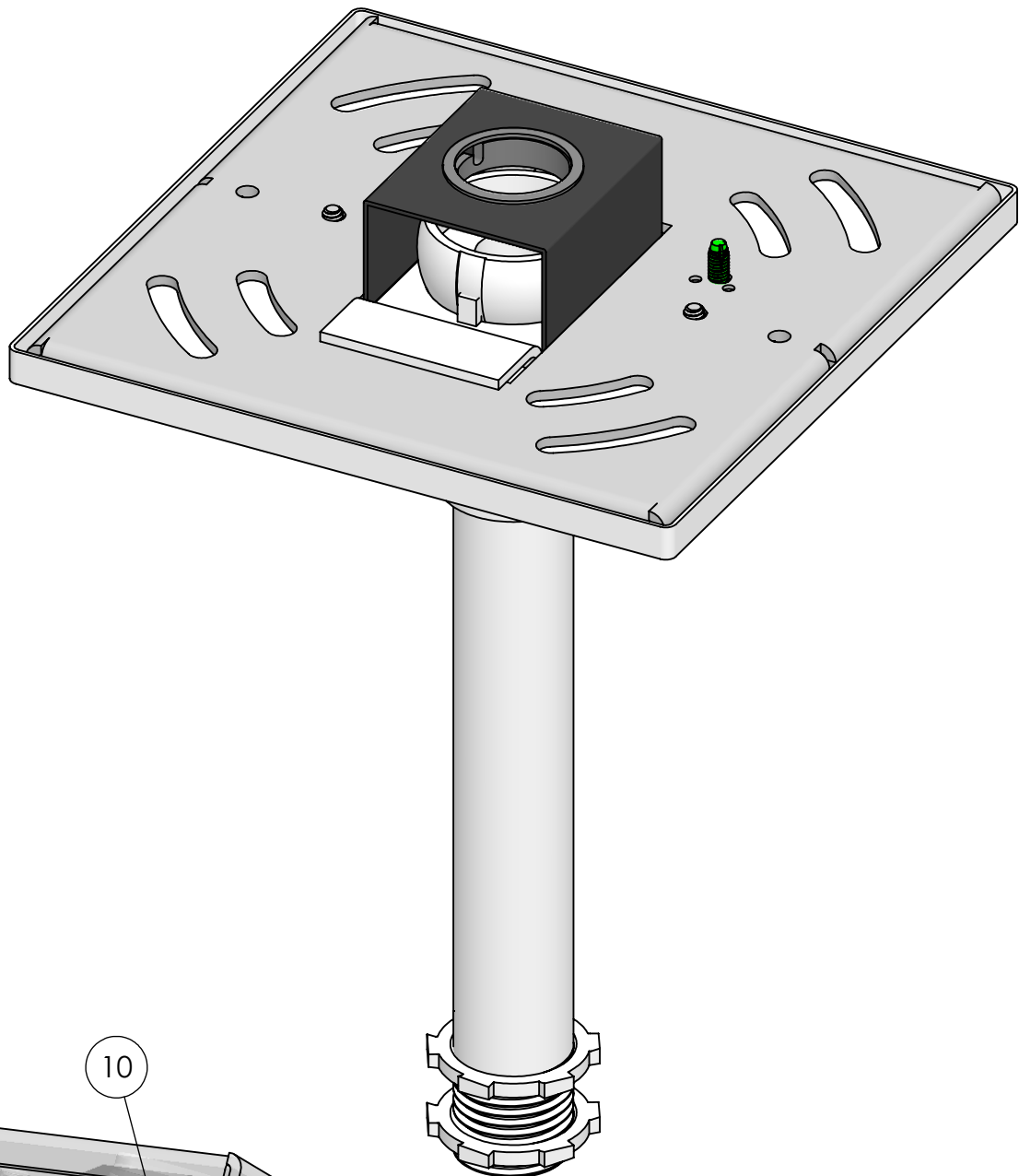

This Document  
Contains Proprietary  
Data that is property  
of Pendant Systems  
which reserves all  
rights to it.  
Unauthorized use  
without authorization  
is prohibited.

# Pendant Systems

1670 Winchester Rd.  
Bensalem, PA 19020  
P-215-638-8552  
F-215-638-8554  
[www.PendantSystems.com](http://www.PendantSystems.com)

UNLESS OTHERWISE SPECIFIED DIMENSIONS ARE IN BOTH INCHES & MILLIMETERS UNLESS OTHERWISE NOTED TOLERANCES:

LINEAR: XX= .02" XXX=  $\pm .010"$  ANGULAR:  $\pm 1$  Degree

FINISH:

TITLE: MP-SW MAG INSTRUCTION

DO NOT SCALE DRAWING  
DEBUR AND BREAK SHARP EDGES

MATERIAL:

Part #

DRAWN DATE: 2/13/17

Drawn By: MWR

SCALE: NTS

SHEET 2 OF 3

REVISION

ITEM NO.	PART NUMBER	DESCRIPTION	QTY.
1	276B SQ	5" Canopy w/1.180" CH	1
2	MP Crossbar	Crossbar 14 Gauge Zinc Plated Steel 4.8" L x 4.8" W x .075" Material Thickness. GS inserted	1
3	MP Plate HB	Monopoint Plate for Half Ball for MP Crossbar 2.82" L x 1.650" W x .075" Material Thickness Half Ball Opening for #35,#34 and #147 Tapped 8/32" Hole Zinc Plated Steel	1
4	183	8/32" x 1/4" Philip Head Ext Sems Steel Zinc Screw	1
5	#147	1/2" IP Tap Half Ball	1
6	#77	1/2" IP Locknut Zinc Plated 1.14"O.D. x .125" H	2
7	Magnet	#6 & #8 Magnet	2
8	271	6/32" x 1/4" L Flat Head Philips Machine Screw	2
9	#32	8/32 Green Ground Screw	1
10	MP Swivel Clip	Mono Point Swivel Retaining Clip for MP-Plate HB Spring Steel	1
11	#237	.875" Hole Bushing .945" W x.750" I.D. x .250" H .063" Max Panel Thickness	1

This Document Contains Proprietary Data that is property of Pendant Systems which reserves all rights to it. Unauthorized use without authorization is prohibited.

## Pendant Systems

1670 Winchester Rd.  
Bensalem, PA 19020  
P-215-638-8552  
F-215-638-8554  
www.PendantSystems.com

UNLESS OTHERWISE SPECIFIED DIMENSIONS ARE IN BOTH INCHES & MILLIMETERS UNLESS OTHERWISE NOTED TOLERANCES:

LINEAR: XX= .02" XXX=  $\pm .010$ " ANGULAR:  $\pm 1$  Degree

FINISH:

TITLE:

Bill of Materials

DO NOT SCALE DRAWING

MATERIAL:

Part #

DEBUR AND BREAK SHARP EDGES

REVISION

DRAWN DATE: 2/13/17

Drawn By: MWR

SCALE: NTS

SHEET 3 OF 3