

ITEM NO.	PART NUMBER	DESCRIPTION	QTY.
1	276	5" Round w/ 1.18" CH	1
2	MP Crossbar Round	4.75" Round Crossbar .080" Material Thickness Zinc Plated Steel	1
3	MP Swivel Clip	Mono Point Swivel Retaining Clip for MP-Plate HB Spring Steel	1
4	#237	.875" Hole Bushing .945" W x .750" I.D. x .250" H .063" Max Panel Thickness	1
5	MP Plate HB	Monopoint Plate for Half Ball for MP Crossbar 2.82" L x 1.650" W x .075" Material Thickness Half Ball Opening for #35, #34 and #147 Tapped 8/32" Hole Zinc Plated Steel	1
6	Magnet	#6 & #8 Magnet	2
7	271	6/32" x 1/4" L Flat Head Philips Machine Screw	2
8	#34	3/8" IP Tap Half Ball	1
9	183	8/32" x 1/4" Philip Head Ext Sems Steel Zinc Screw	1
10	#32	8/32 Green Ground Screw	1
11	#22	3/8" IP x 1 1/16" Square x .073" Thick Zinc Plated	2

**STEM LENGTH WILL VARY. ORDER SEPARATELY
MP SW3/8 RD MAG USED WITH STEM 3/8" IP
3/8" IPS .625"-.635" O.D. 18 T.P.I.**

***38° SWIVEL**

This Document Contains Proprietary Data that is property of Pendant Systems which reserves all rights to it. Unauthorized use without authorization is prohibited.

Pendant Systems
1670 Winchester Rd.
Bensalem, PA 19020
P-215-638-8552
F-215-638-8554
www.PendantSystems.com

UNLESS OTHERWISE SPECIFIED DIMENSIONS ARE IN BOTH INCHES & MILLIMETERS UNLESS OTHERWISE NOTED TOLERANCES: LINEAR: XX= .02" XXX= $\pm .010$ " ANGULAR: ± 1 Degree		FINISH:	TITLE: MP SW 3-8 RD MAG
DO NOT SCALE DRAWING	MATERIAL:	Part #	REVISION
DEBUR AND BREAK SHARP EDGES		SCALE: NTS	SHEET 1 OF 2
DRAWN DATE: 11/18/16	Drawn By: MWR		

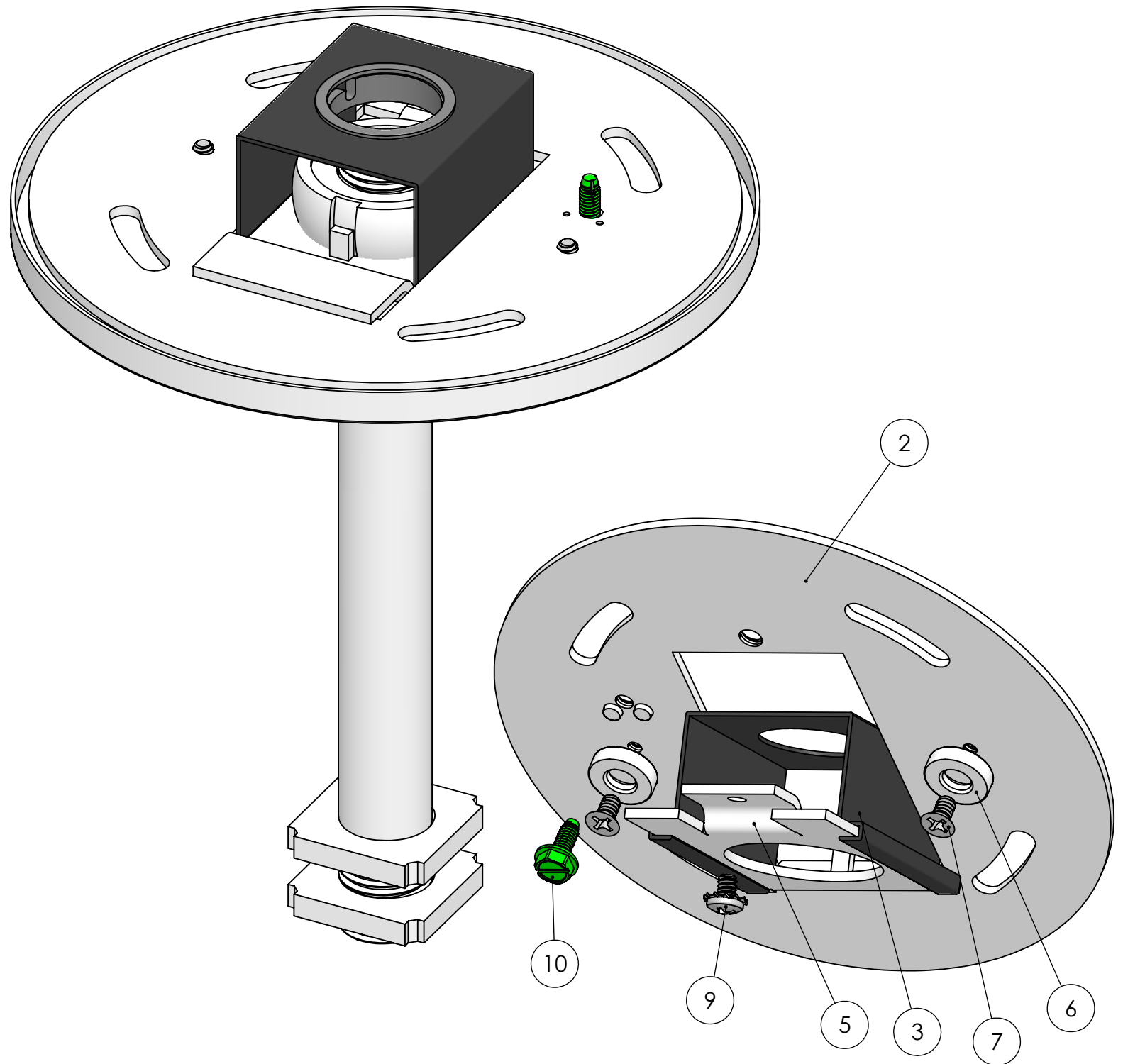

This Document
Contains Proprietary
Data that is property
of Pendant Systems
which reserves all
rights to it.
Unauthorized use
without authorization
is prohibited.

Pendant Systems
1670 Winchester Rd.
Bensalem, PA 19020
P-215-638-8552
F-215-638-8554
www.PendantSystems.com

UNLESS OTHERWISE SPECIFIED DIMENSIONS ARE IN BOTH INCHES & MILLIMETERS UNLESS OTHERWISE NOTED TOLERANCES:
LINEAR: XX= .02" XXX= \pm .010" ANGULAR: \pm 1 Degree

FINISH:

TITLE:
MP SW 3-8 RD MAG Assembled

DO NOT SCALE DRAWING
DEBUR AND BREAK SHARP EDGES

MATERIAL:

Part #

DRAWN DATE: 11/18/16

Drawn By: MWR

SCALE: NTS

SHEET 2 OF 2

REVISION