

**\*Reference Bill of Materials on Page 3**

STEM LENGTH WILL VARY. ORDER SEPARATELY  
 MP SW 1/8 MAG ADJ USED WITH STEM 1/8" IP  
 1/8" IPS .375"-.380" O.D. 27 T.P.I

\*41° SWIVEL

This Document  
 Contains Proprietary  
 Data that is property  
 of Pendant Systems  
 which reserves all  
 rights to it.  
 Unauthorized use  
 without authorization  
 is prohibited.

**Pendant Systems**

1670 Winchester Rd.  
 Bensalem, PA 19020  
 P-215-638-8552  
 F-215-638-8554  
 www.PendantSystems.com

UNLESS OTHERWISE SPECIFIED DIMENSIONS ARE IN BOTH INCHES &  
 MILLIMETERS UNLESS OTHERWISE NOTED TOLERANCES:

LINEAR: XX= .02" XXX=  $\pm .010$ " ANGULAR:  $\pm 1$  Degree

FINISH:

TITLE:

MP-SW1-8 MAG ADJ

DO NOT SCALE DRAWING

MATERIAL:

Part #

DEBUR AND BREAK SHARP EDGES

REVISION

DRAWN DATE: 2/13/17

Drawn By: MWR

SCALE: NTS

SHEET 1 OF 3

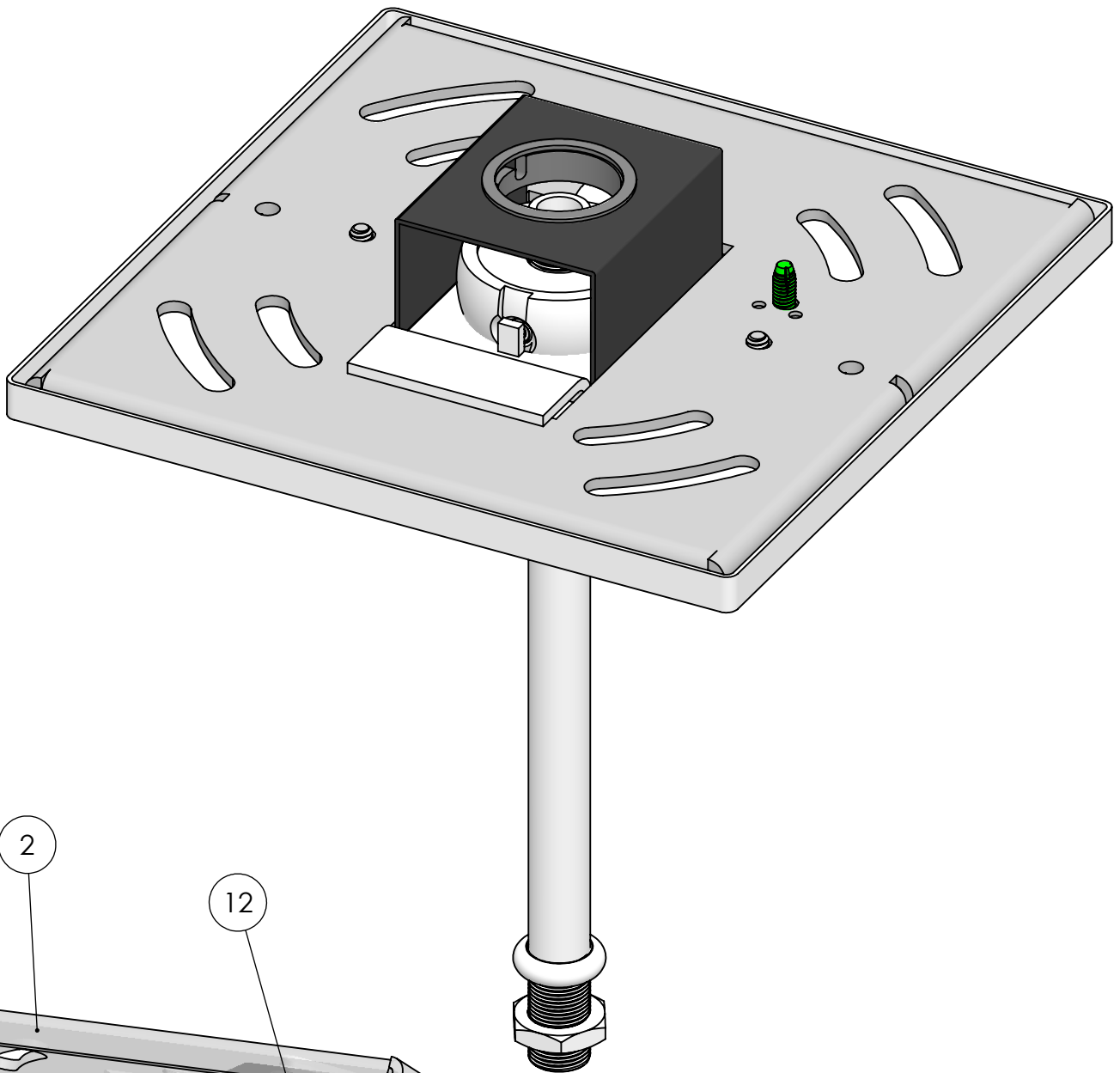

This Document  
Contains Proprietary  
Data that is property  
of Pendant Systems  
which reserves all  
rights to it.  
Unauthorized use  
without authorization  
is prohibited.

# Pendant Systems

1670 Winchester Rd.  
Bensalem, PA 19020  
P-215-638-8552  
F-215-638-8554  
[www.PendantSystems.com](http://www.PendantSystems.com)

UNLESS OTHERWISE SPECIFIED DIMENSIONS ARE IN BOTH INCHES & MILLIMETERS UNLESS OTHERWISE NOTED TOLERANCES:

LINEAR: XX= .02" XXX=  $\pm .010"$  ANGULAR:  $\pm 1$  Degree

FINISH:

MATERIAL:

TITLE:

MP-SW MAG INSTRUCTION

Part #

DO NOT SCALE DRAWING  
DEBUR AND BREAK SHARP EDGES

DRAWN DATE: 2/13/17

Drawn By: MWR

SCALE: NTS

SHEET 2 OF 3

REVISION

ITEM NO.	PART NUMBER	DESCRIPTION	QTY.
1	276B SQ	5" Canopy w/1.180" CH	1
2	MP Crossbar	Crossbar 14 Gauge Zinc Plated Steel 4.8" L x 4.8" W x .075" Material Thickness. GS inserted	1
3	MP Plate HB	Monopoint Plate for Half Ball for MP Crossbar 2.82" L x 1.650" W x .075" Material Thickness Half Ball Opening for #35, #34 and #147 Tapped 8/32" Hole Zinc Plated Steel	1
4	183	8/32" x 1/4" Philip Head Ext Sems Steel Zinc Screw	1
5	#272 ADJ	1/8" IP Slip Half Ball Bright Casting	1
6	#133	1/8" IP x 9/16" O.D. x 1/8" Thick Zinc Plated	1
7	Magnet	#6 & #8 Magnet	2
8	271	6/32" x 1/4" L Flat Head Philips Machine Screw	2
9	273	8/32" x .3235" L Half Dog Point Allen Set Screw	2
10	#32	8/32 Green Ground Screw	1
11	MP Swivel Clip	Mono Point Swivel Retaining Clip for MP-Plate HB Spring Steel	1
12	#237	.875" Hole Bushing .945" W x .750" I.D. x .250" H .063" Max Panel Thickness	1

This Document Contains Proprietary Data that is property of Pendant Systems which reserves all rights to it. Unauthorized use without authorization is prohibited.

## Pendant Systems

1670 Winchester Rd.  
Bensalem, PA 19020  
P-215-638-8552  
F-215-638-8554  
[www.PendantSystems.com](http://www.PendantSystems.com)

UNLESS OTHERWISE SPECIFIED DIMENSIONS ARE IN BOTH INCHES & MILLIMETERS UNLESS OTHERWISE NOTED TOLERANCES:

LINEAR: XX= .02" XXX=  $\pm$ .010" ANGULAR:  $\pm$  1 Degree

FINISH:

TITLE:

Bill of Materials

DO NOT SCALE DRAWING

MATERIAL:

Part #

DEBUR AND BREAK SHARP EDGES

REVISION

DRAWN DATE: 2/13/17

Drawn By: MWR

SCALE: NTS

SHEET 3 OF 3