

ITEM NO.	PART NUMBER	DESCRIPTION	QTY.
1	276	5" Round w/ 1.18" CH	1
2	MP Crossbar Round	4.75" Round Crossbar .080" Material Thickness Zinc Plated Steel	1
3	MP Swivel Clip	Mono Point Swivel Retaining Clip for MP-Plate HB Spring Steel	1
4	#237	.875" Hole Bushing .945" W x .750" I.D. x .250" H .063" Max Panel Thickness	1
5	MP Plate HB	Monopoint Plate for Half Ball for MP Crossbar 2.82" L x 1.650" W x .075" Material Thickness Half Ball Opening for #35, #34 and #147 Tapped 8/32" Hole Zinc Plated Steel	1
6	Magnet	#6 & #8 Magnet	2
7	271	6/32" x 1/4" L Flat Head Philips Machine Screw	2
8	183	8/32" x 1/4" Philip Head Ext Sems Steel Zinc Screw	1
9	#272 ADJ	1/8" IP Slip Half Ball Bright Casting	1
10	#133	1/8" IP x 9/16" O.D. x 1/8" Thick Zinc Plated	1
11	#32	8/32 Green Ground Screw	1
12	273	8/32" x .3235" L Half Dog Point Allen Set Screw	2
13	5/64" Tool Kit	5/64" Allen Wrench & 1/8" Drill Bit	1

STEM LENGTH WILL VARY. ORDER SEPARATELY
 MP SW 1/8 RD MAG ADJ TK USED WITH STEM
 1/8" IP
 1/8" IPS .375"-.380" O.D. 27 T.P.I

*41° SWIVEL

This Document
 Contains Proprietary
 Data that is property
 of Pendant Systems
 which reserves all
 rights to it.
 Unauthorized use
 without authorization
 is prohibited.

Pendant Systems

1670 Winchester Rd.
 Bensalem, PA 19020
 P-215-638-8552
 F-215-638-8554
www.PendantSystems.com

UNLESS OTHERWISE SPECIFIED DIMENSIONS ARE IN BOTH INCHES & MILLIMETERS UNLESS OTHERWISE NOTED TOLERANCES:

LINEAR: XX= .02" XXX= $\pm .010"$ ANGULAR: ± 1 Degree

FINISH:

TITLE:

MP SW 1-8 RD MAG ADJ TK

DO NOT SCALE DRAWING

MATERIAL:

Part #

DEBUR AND BREAK SHARP EDGES

REVISION

DRAWN DATE: 2/2/17

Drawn By: MWR

SCALE: NTS

SHEET 1 OF 2

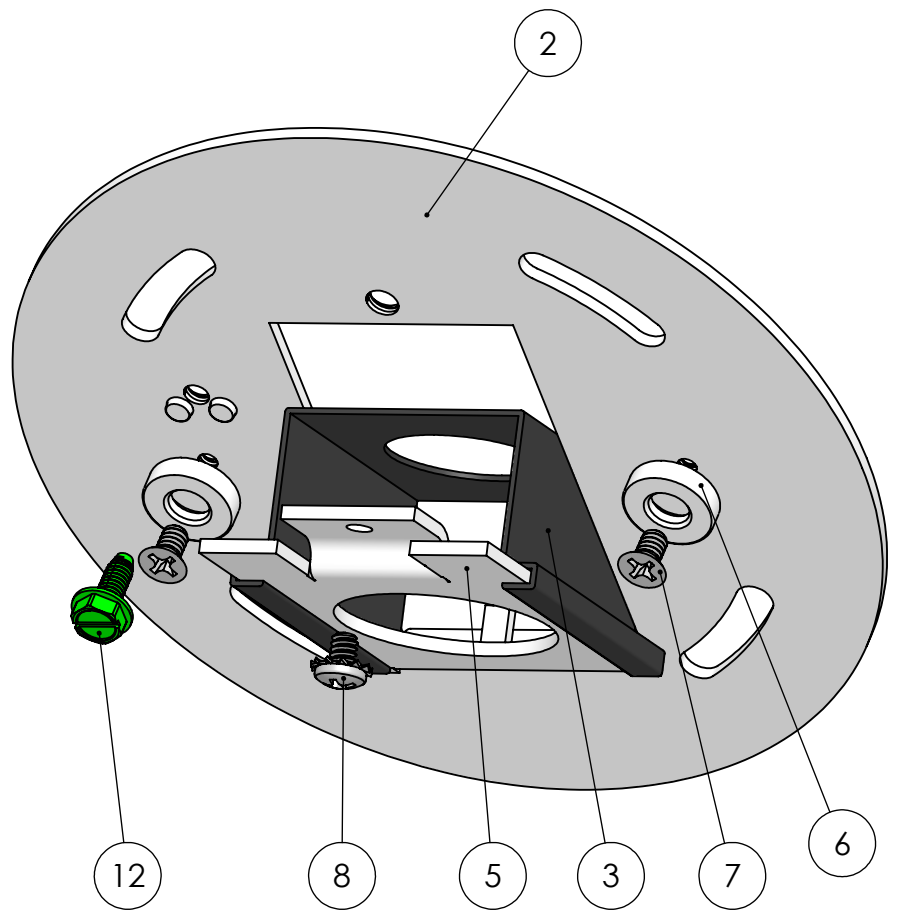
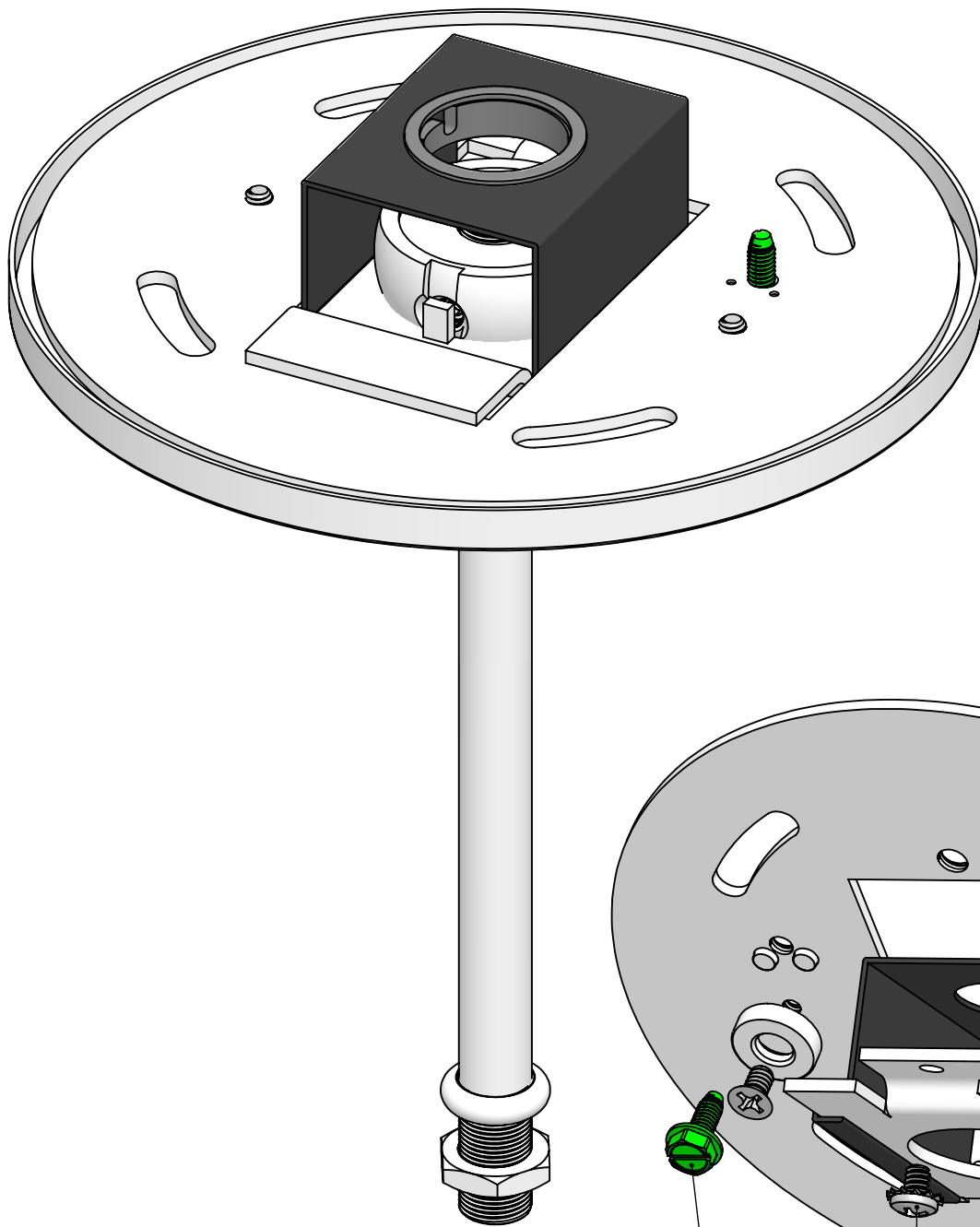

This Document
Contains Proprietary
Data that is property
of Pendant Systems
which reserves all
rights to it.
Unauthorized use
without authorization
is prohibited.

Pendant Systems

1670 Winchester Rd.
Bensalem, PA 19020
P-215-638-8552
F-215-638-8554
www.PendantSystems.com

UNLESS OTHERWISE SPECIFIED DIMENSIONS ARE IN BOTH INCHES & MILLIMETERS UNLESS OTHERWISE NOTED TOLERANCES:

LINEAR: XX= .02" XXX= $\pm .010"$ ANGULAR: ± 1 Degree

FINISH:

TITLE:

MP SW 1-8 RD MAG ADJ TK Assembled

DO NOT SCALE DRAWING

MATERIAL:

Part #

DEBUR AND BREAK SHARP EDGES

REVISION

DRAWN DATE: 2/2/17

Drawn By: MWR

SCALE: NTS

SHEET 2 OF 2