

ITEM NO.	PART NUMBER	DESCRIPTION	QTY.
1	276	5" Round w/ 1.18" CH	1
2	MP Crossbar Round	4.75" Round Crossbar .080" Material Thickness Zinc Plated Steel	1
3	#35	1/4" IP Tap Half Ball	1
4	MP Plate HB	Monopoint Plate for Half Ball for MP Crossbar 2.82" L x 1.650" W x .075" Material Thickness Half Ball Opening for #35, #34 and #147 Tapped 8/32" Hole Zinc Plated Steel	1
5	MP Swivel Clip	Mono Point Swivel Retaining Clip for MP-Plate HB Spring Steel	1
6	#237	.875" Hole Bushing .945" W x .750" I.D. x .250" H .063" Max Panel Thickness	1
7	Magnet	#6 & #8 Magnet	2
8	271	6/32" x 1/4" L Flat Head Philips Machine Screw	2
9	183	8/32" x 1/4" Philip Head Ext Sems Steel Zinc Screw	1
10	60-1.5	1/8" IP Nipple 1" L	1
11	#133	1/8" IP x 9/16" O.D. x 1/8" Thick Zinc Plated	1
12	#32	8/32 Green Ground Screw	1

STEM LENGTH WILL VARY. ORDER SEPARATELY
MP SW 1/4 RD MAG ID USED WITH STEM 1/4" IP
1/4" IPS .500"-.510" O.D. 18 T.P.I.
Add Suffix WHT for White or Bk for Black

*45° SWIVEL

This Document Contains Proprietary Data that is property of Pendant Systems which reserves all rights to it. Unauthorized use without authorization is prohibited.

Pendant Systems
1670 Winchester Rd.
Bensalem, PA 19020
P-215-638-8552
F-215-638-8554
www.PendantSystems.com

UNLESS OTHERWISE SPECIFIED DIMENSIONS ARE IN BOTH INCHES & MILLIMETERS UNLESS OTHERWISE NOTED TOLERANCES: LINEAR: XX= .02" XXX= ±.010" ANGULAR: ± 1 Degree		FINISH:		TITLE: MP SW 1-4 RD MAG ID	
DO NOT SCALE DRAWING		MATERIAL:		Part #	
DEBUR AND BREAK SHARP EDGES				REVISION	
DRAWN DATE: 4/4/17		Drawn By: MWR		SCALE: NTS SHEET 1 OF 2	

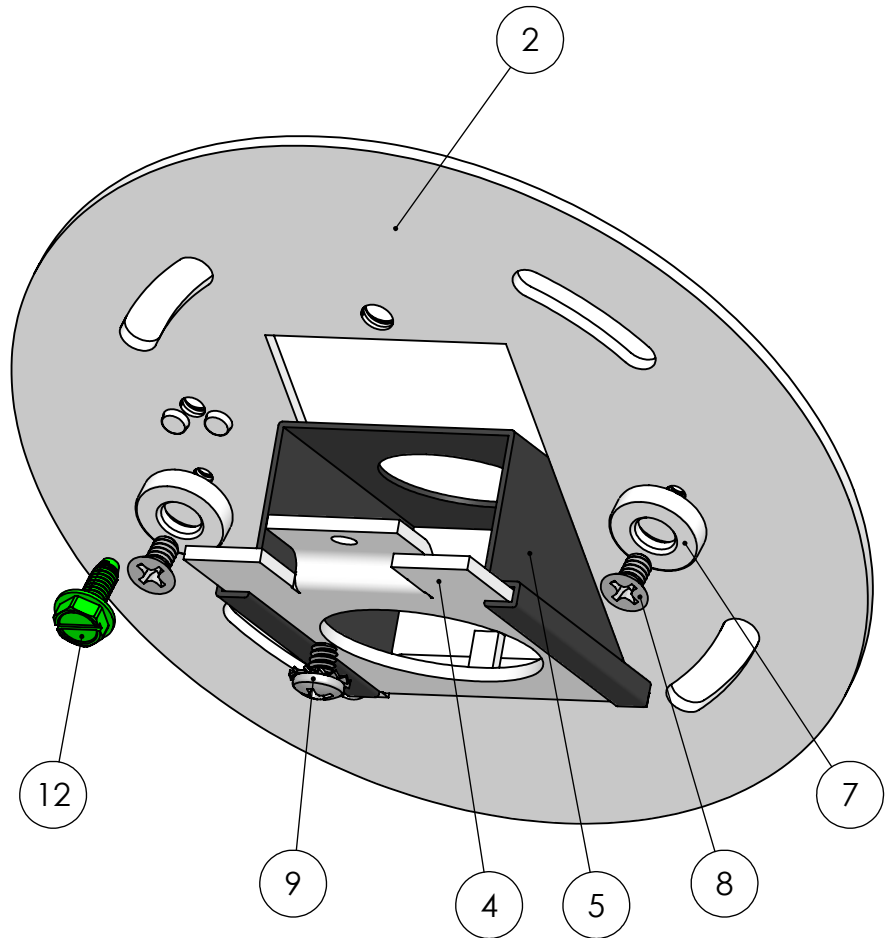
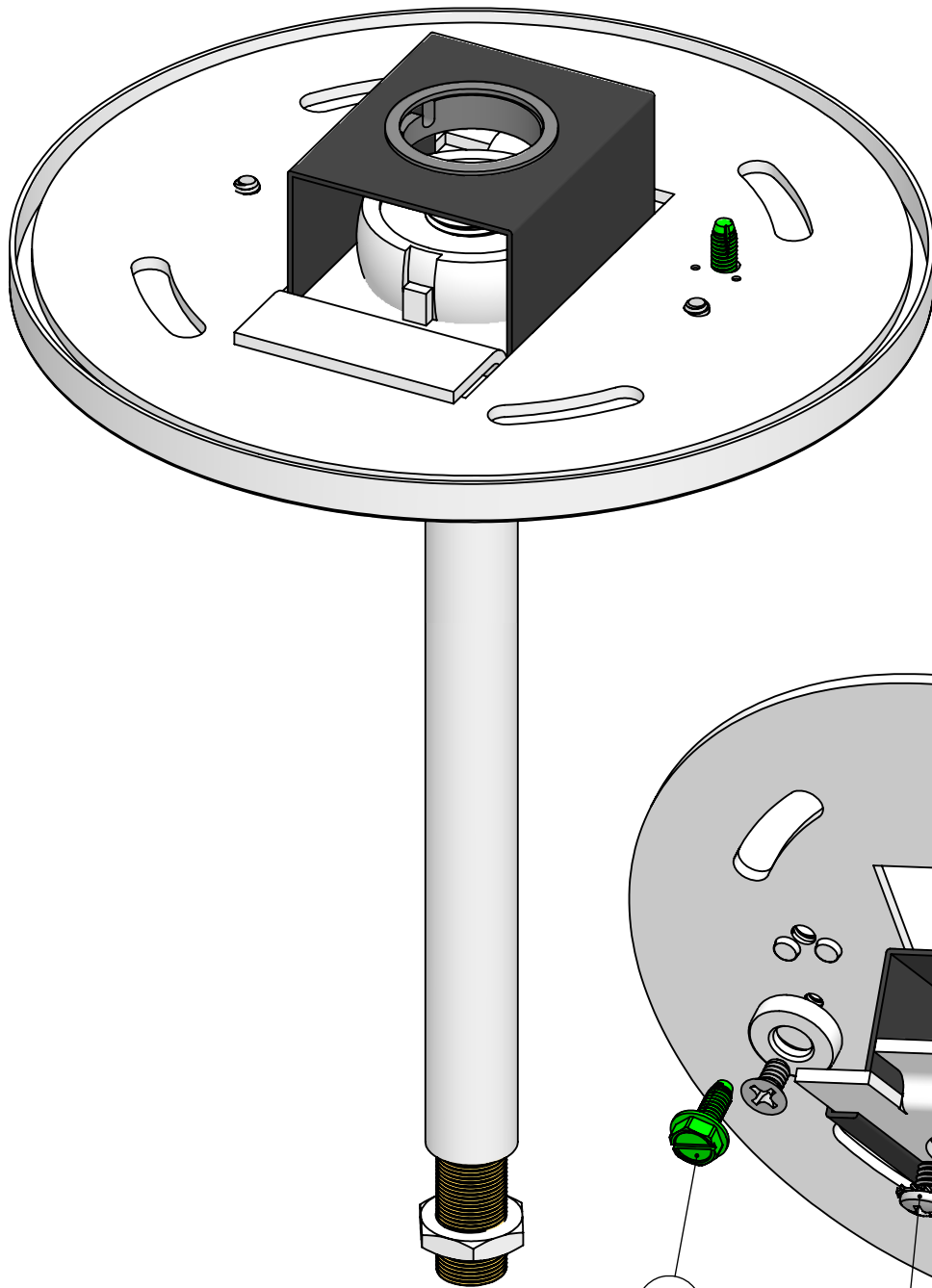

This Document
Contains Proprietary
Data that is property
of Pendant Systems
which reserves all
rights to it.
Unauthorized use
without authorization
is prohibited.

Pendant Systems

1670 Winchester Rd.
Bensalem, PA 19020
P-215-638-8552
F-215-638-8554
www.PendantSystems.com

UNLESS OTHERWISE SPECIFIED DIMENSIONS ARE IN BOTH INCHES & MILLIMETERS UNLESS OTHERWISE NOTED TOLERANCES:

LINEAR: XX= .02" XXX= \pm .010" ANGULAR: \pm 1 Degree

FINISH:

TITLE:

MP SW 1-4 RD MAG ID Assembled

DO NOT SCALE DRAWING

MATERIAL:

Part #

DEBUR AND BREAK SHARP EDGES

REVISION

DRAWN DATE: 4/4/17

Drawn By: MWR

SCALE: NTS

SHEET 2 OF 2