

ITEM NO.	PART NUMBER	DESCRIPTION	QTY.
1	#243B RM	5" Round	1
2	MP Crossbar Round	4.75" Round Crossbar .080" Material Thickness Zinc Plated Steel	1
3	MP Plate HB	Monopoint Plate for Half Ball for MP Crossbar 2.82" L x 1.650" W x .075" Material Thickness Half Ball Opening for #35, #34 and #147 Tapped 8/32" Hole Zinc Plated Steel	1
4	183	8/32" x 1/4" Philip Head Ext Sems Steel Zinc Screw	1
5	MP Swivel Clip	Mono Point Swivel Retaining Clip for MP-Plate HB Spring Steel	1
6	#237	.875" Hole Bushing .945" W x .750" I.D. x .250" H .063" Max Panel Thickness	1
7	#35ADJ	1/4" IP Slip Half Ball Bright Casting	1
8	#60-1	1/8" IP Nipple 1" L	1
9	#133	1/8" IP x 9/16" O.D. x 1/8" Thick Zinc Plated	1
10	MP Screws	6/32" x 3/4" Long Zinc Plated Flat Countersunk Head Machine Screw. Available with White, Black or Zinc Finished Heads	2
11	#32	8/32 Green Ground Screw	1
12	#SSS	1/4" -20 Socket Set Screw w/.125 DIA & 1/8" Allen Hex Head Pin for ADJ Series Half Balls	1
13	#ADJ-SS	1/4" -20 Short (.350" Long) Socket Set Screw w/.125" DIA Point & 1/8" Allen Hex Head Pin for ADJ Series Half Balls	1
14	ADJ Tool Kit	Drill Bit 1/8" & Allen Wrench 1/8"	1

STEM LENGTH WILL VARY. ORDER SEPARATELY
 MP SW 1/4 RD ADJ ID TK USED WITH
 STEM 1/4" IP I.D. PH
 1/4" IPS .500"-.510" O.D. 18 T.P.I

This Document
 Contains Proprietary
 Data that is property
 of Pendant Systems
 which reserves all
 rights to it.
 Unauthorized use
 without authorization
 is prohibited.

Pendant Systems
 1670 Winchester Rd.
 Bensalem, PA 19020
 P-215-638-8552
 F-215-638-8554
 www.PendantSystems.com

UNLESS OTHERWISE SPECIFIED DIMENSIONS ARE IN BOTH INCHES & MILLIMETERS UNLESS OTHERWISE NOTED TOLERANCES: LINEAR: XX= .02" XXX= ±.010" ANGULAR: ± 1 Degree		FINISH:		TITLE: MP SW 1-4 RD ADJ TK ID	
DO NOT SCALE DRAWING		MATERIAL:		Part #	
DEBUR AND BREAK SHARP EDGES				REVISION	
DRAWN DATE: 5/17/17		Drawn By: MWR		SCALE: NTS SHEET 1 OF 2	

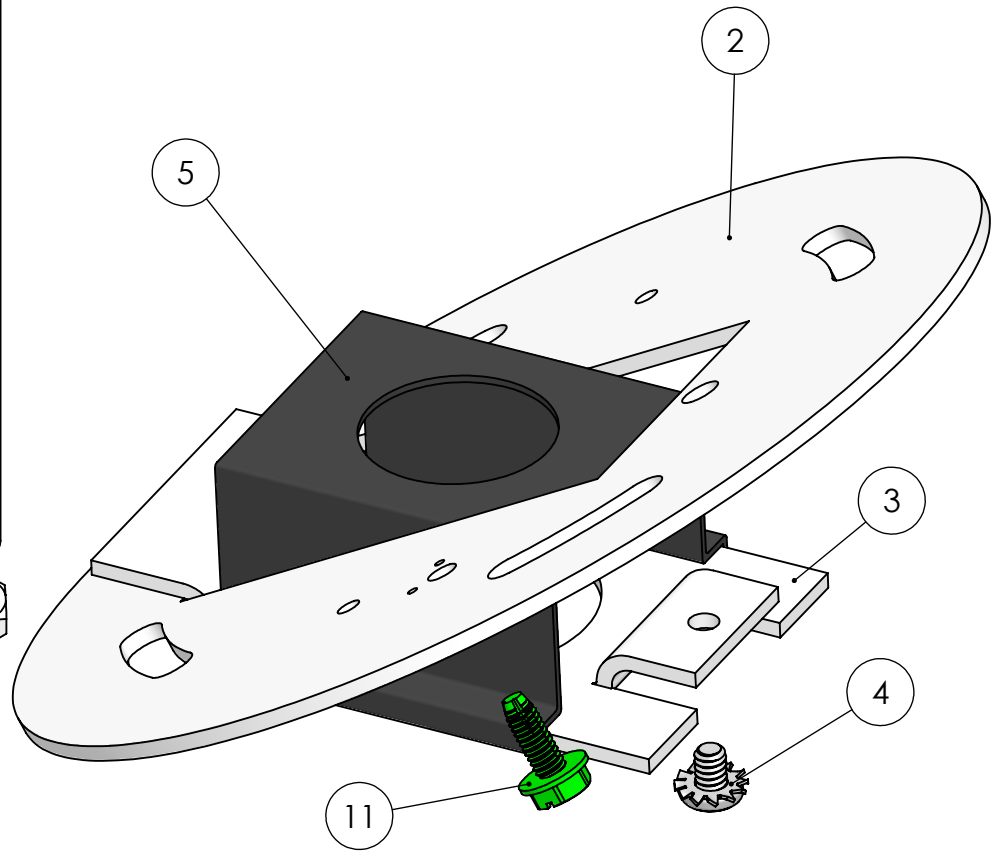
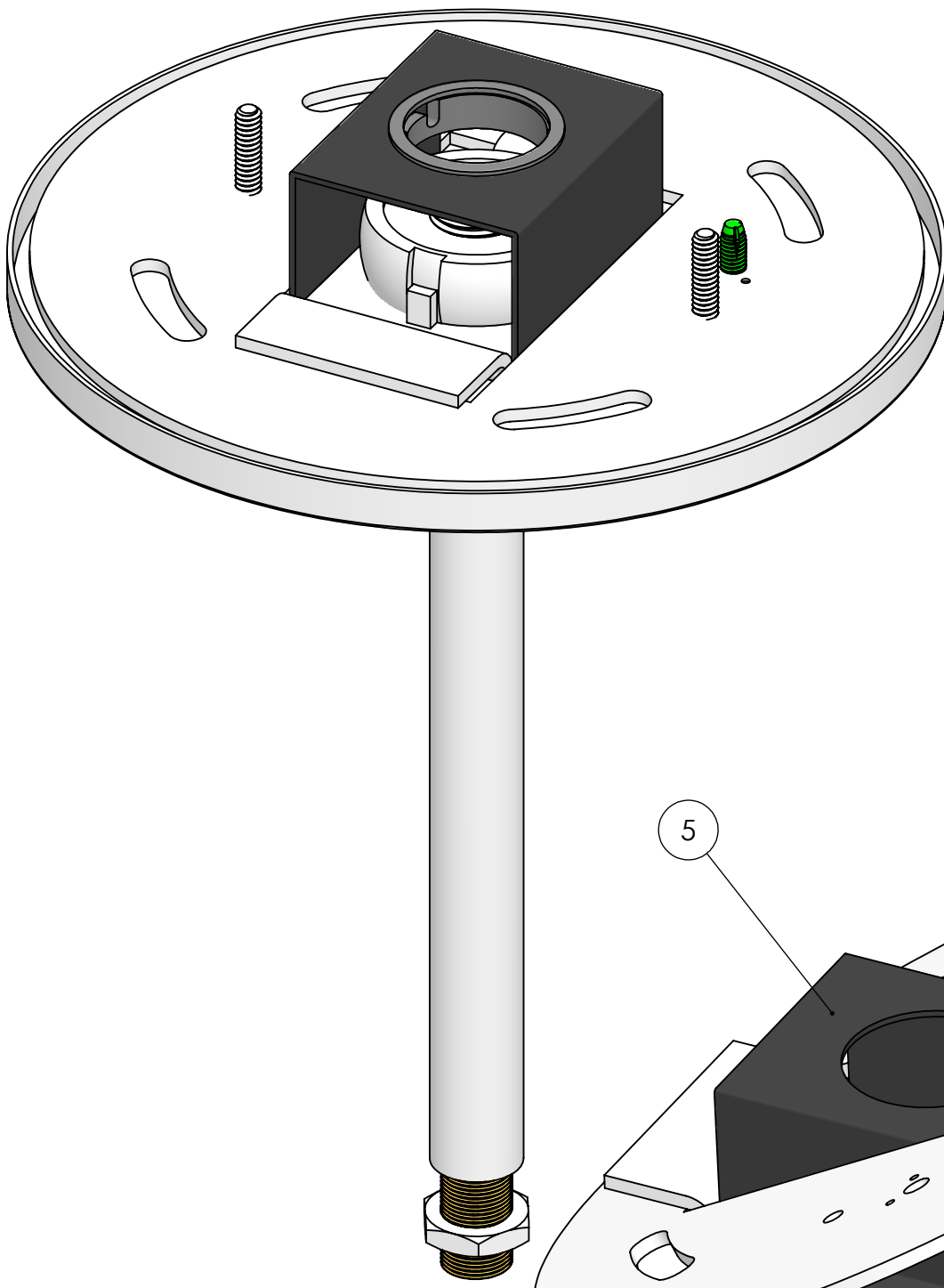

This Document
Contains Proprietary
Data that is property
of Pendant Systems
which reserves all
rights to it.
Unauthorized use
without authorization
is prohibited.

Pendant Systems
1670 Winchester Rd.
Bensalem, PA 19020
P-215-638-8552
F-215-638-8554
www.PendantSystems.com

UNLESS OTHERWISE SPECIFIED DIMENSIONS ARE IN BOTH INCHES & MILLIMETERS UNLESS OTHERWISE NOTED TOLERANCES:
LINEAR: XX= .02" XXX= $\pm .010"$ ANGULAR: ± 1 Degree

FINISH:
MATERIAL:

TITLE:
MP SW 1-4 RD ADJ TK ID Assembled

DO NOT SCALE DRAWING
DEBUR AND BREAK SHARP EDGES

MATERIAL:

Part #
SCALE: NTS
SHEET 2 OF 2
REVISION

DRAWN DATE: 5/17/17

Drawn By: MWR

SCALE: NTS
SHEET 2 OF 2
REVISION