

***Reference Bill of Materials on Page 3**

STEM LENGTH WILL VARY. ORDER SEPARATELY
 MP-ST1/4 MAG ID USED WITH
 STEM 1/4" IP O.D.-I.D.
 1/4" IPS .500"-.510" O.D. 18 T.P.I

This Document
 Contains Proprietary
 Data that is property
 of Pendant Systems
 which reserves all
 rights to it.
 Unauthorized use
 without authorization
 is prohibited.

Pendant Systems

1670 Winchester Rd.
 Bensalem, PA 19020
 P-215-638-8552
 F-215-638-8554
 www.PendantSystems.com

UNLESS OTHERWISE SPECIFIED DIMENSIONS ARE IN BOTH INCHES &
 MILLIMETERS UNLESS OTHERWISE NOTED TOLERANCES:

LINEAR: XX= .02" XXX= \pm .010" ANGULAR: \pm 1 Degree

FINISH:

TITLE:

MP-ST1-4 MAG ID

DO NOT SCALE DRAWING

MATERIAL:

Part #

DEBUR AND BREAK SHARP EDGES

REVISION

DRAWN DATE: 5/16/17

Drawn By: MWR

SCALE: NTS

SHEET 1 OF 3

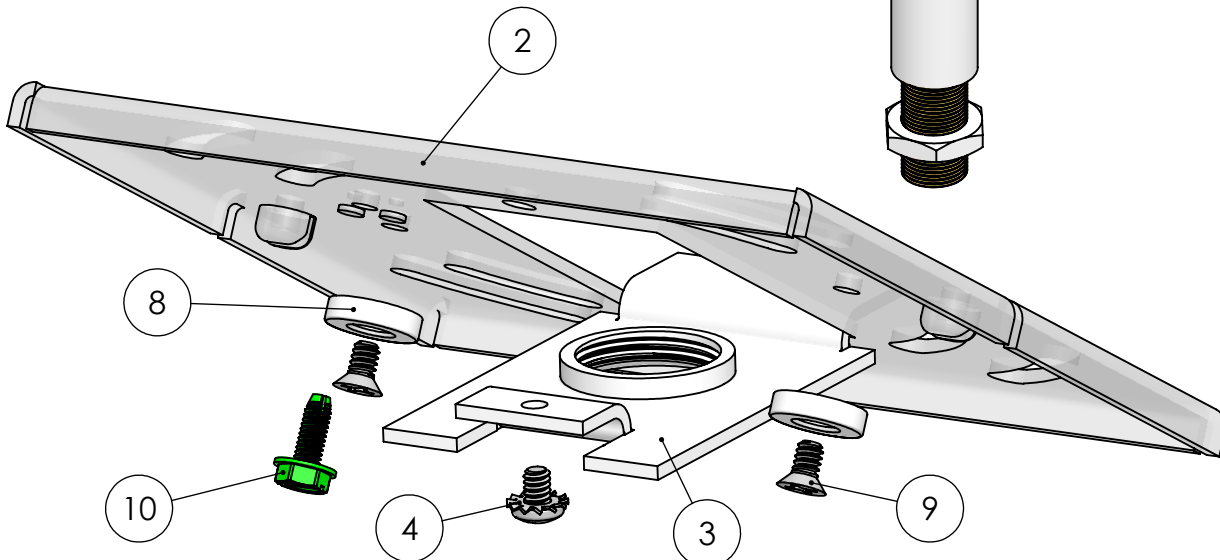
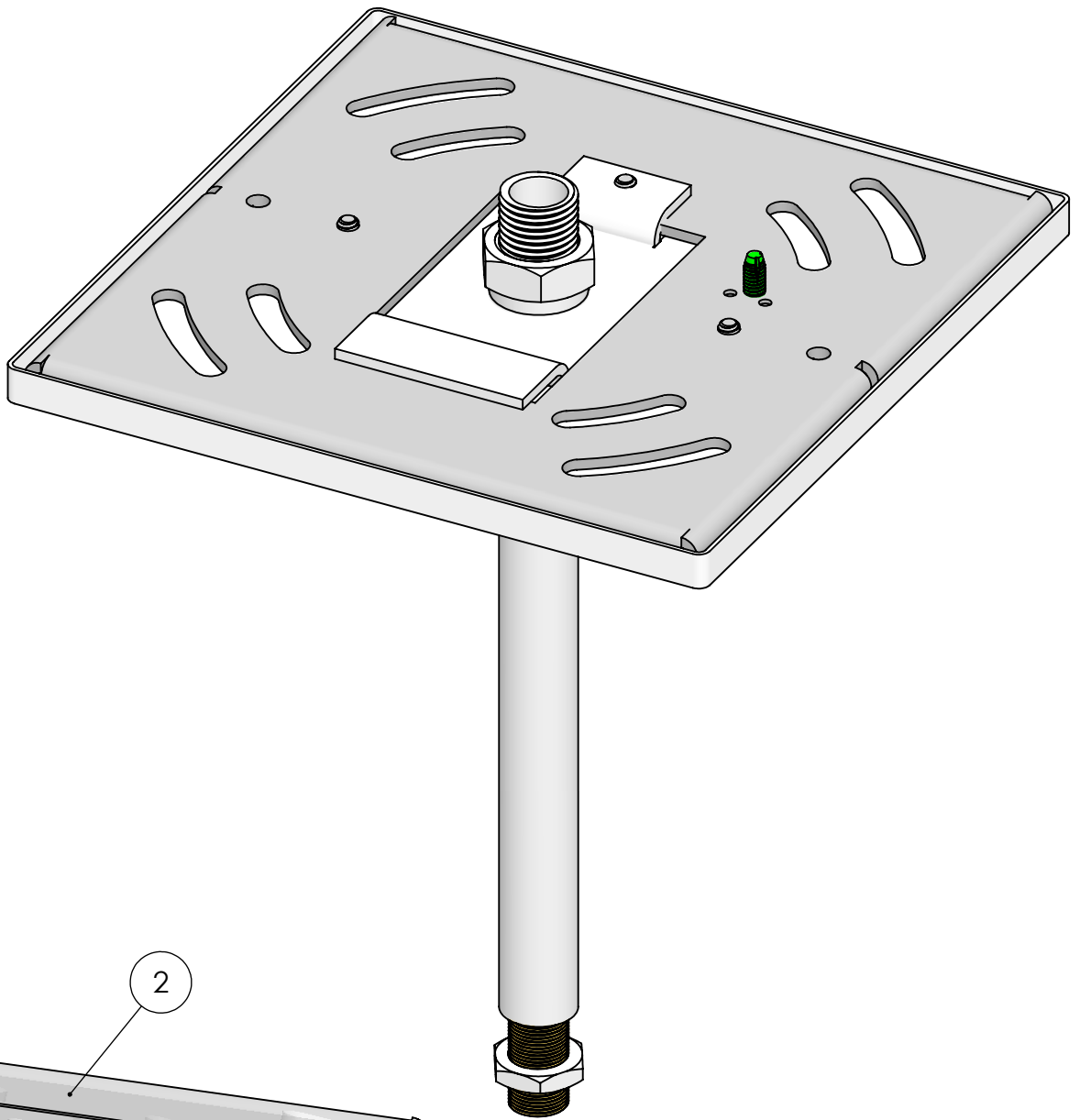

This Document
Contains Proprietary
Data that is property
of Pendant Systems
which reserves all
rights to it.
Unauthorized use
without authorization
is prohibited.

Pendant Systems

1670 Winchester Rd.
Bensalem, PA 19020
P-215-638-8552
F-215-638-8554
www.PendantSystems.com

UNLESS OTHERWISE SPECIFIED DIMENSIONS ARE IN BOTH INCHES & MILLIMETERS UNLESS OTHERWISE NOTED TOLERANCES:
LINEAR: XX= .02" XXX= $\pm .010"$ ANGULAR: ± 1 Degree

FINISH:

TITLE: MP-ST1-4 MAG ID Assembled

DO NOT SCALE DRAWING
DEBUR AND BREAK SHARP EDGES

MATERIAL:

Part #

REVISION

DRAWN DATE: 5/16/17

Drawn By: MWR

SCALE: NTS

SHEET 2 OF 3

ITEM NO.	PART NUMBER	DESCRIPTION	QTY.
1	278B SQ	5" Canopy w/.530" CH	1
2	MP Crossbar	Crossbar 14 Gauge Zinc Plated Steel 4.8" L x 4.8" W x .075" Material Thickness	1
3	MP Plate 1-4 IP	1/4" IP Monopoint Plate for MP Crossbar 2.82" L x 1.650" W x .075" Material Thickness Tapped 8/32" Hole Zinc Plated Steel	1
4	183	8/32" x 1/4" Philip Head Ext Sems Steel Zinc Screw	1
5	#64	1/4" IP x 3/4 O.D. x 1/4" Thick Zinc Plated	1
6	#60-1	1/8" IP Nipple 1" L	1
7	#133	1/8" IP x 9/16" O.D. x 1/8" Thick Zinc Plated	1
8	Magnet	#6 & #8 Magnet	2
9	271	6/32" x 1/4" L Flat Head Philips Machine Screw	2
10	#32	8/32 Green Ground Screw	1

This Document Contains Proprietary Data that is property of Pendant Systems which reserves all rights to it. Unauthorized use without authorization is prohibited.

Pendant Systems

1670 Winchester Rd.
Bensalem, PA 19020
P-215-638-8552
F-215-638-8554
www.PendantSystems.com

UNLESS OTHERWISE SPECIFIED DIMENSIONS ARE IN BOTH INCHES & MILLIMETERS UNLESS OTHERWISE NOTED TOLERANCES:

LINEAR: XX= .02" XXX= \pm .010" ANGULAR: \pm 1 Degree

FINISH:

TITLE:

Bill of Materials

DO NOT SCALE DRAWING

MATERIAL:

Part #

DEBUR AND BREAK SHARP EDGES

REVISION

DRAWN DATE: 5/16/17

Drawn By: MWR

SCALE: NTS

SHEET 3 OF 3