

ITEM NO.	PART NUMBER	DESCRIPTION	QTY.
1	#217	8/32" x 5/16" Philips Flat Machine Screw	2
2	TC Base-1	.964" L x 1" W	1
3	TC1/4" IP	Track Clip 1/4" IP 1.940" L x 1" W	1

This Document Contains Proprietary Data that is property of Pendant Systems which reserves all rights to it. Unauthorized use without authorization is prohibited.

Pendant Systems
 1670 Winchester Rd.
 Bensalem, PA 19020
 P-215-638-8552
 F-215-638-8554
 www.PendantSystems.com

UNLESS OTHERWISE SPECIFIED DIMENSIONS ARE IN BOTH INCHES & MILLIMETERS UNLESS OTHERWISE NOTED TOLERANCES:
 LINEAR: XX= .02" XXX= $\pm .010"$ ANGULAR: ± 1 Degree

FINISH:

TITLE: Track Clip Kit 1-4

DO NOT SCALE DRAWING
 DEBUR AND BREAK SHARP EDGES

MATERIAL:

Part #

DRAWN DATE: 5/10/16

Drawn By: MWR

SCALE: NTS

SHEET 1 OF 2

REVISION

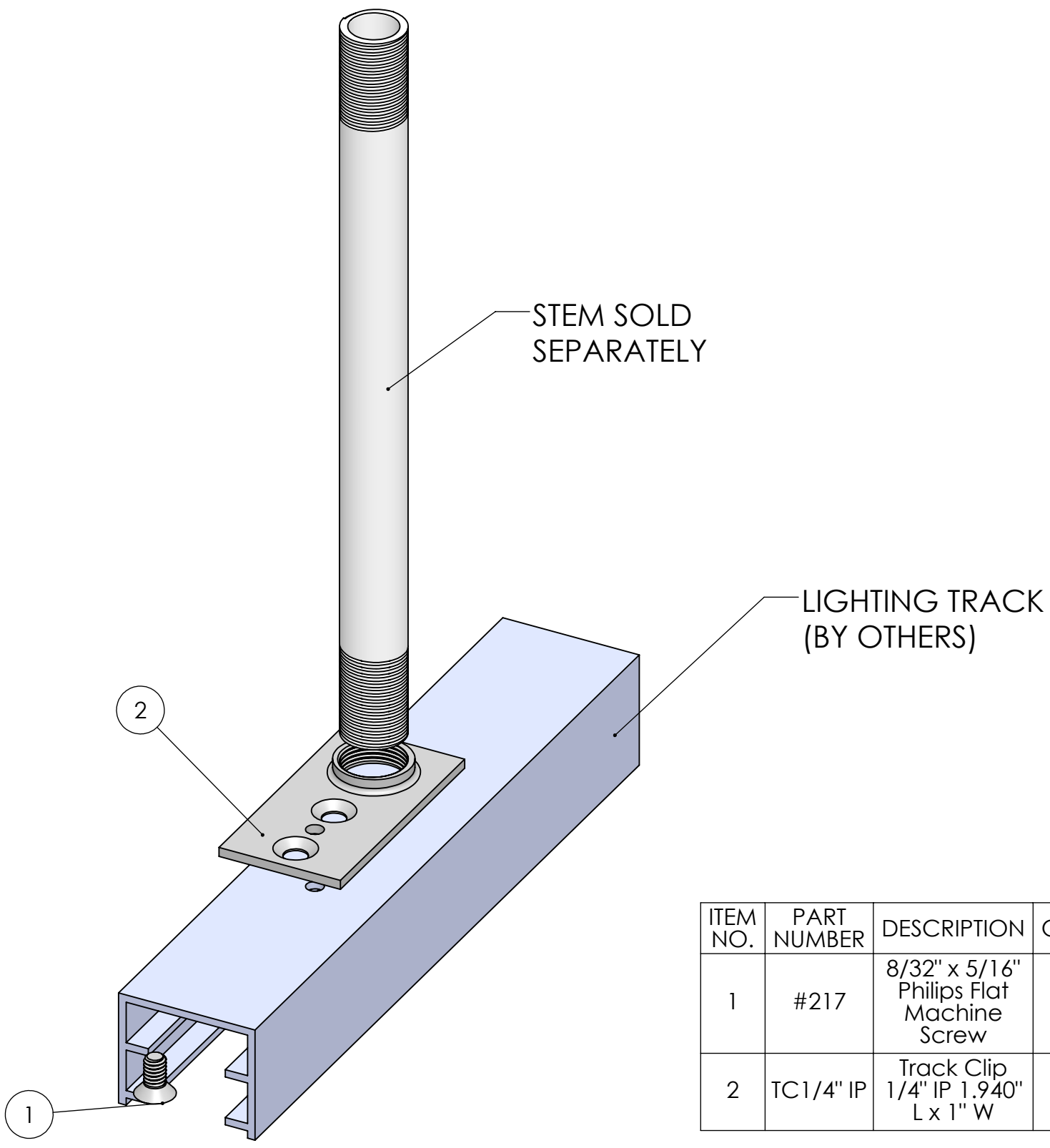

ITEM NO.	PART NUMBER	DESCRIPTION	QTY.
1	#217	8/32" x 5/16" Philips Flat Machine Screw	1
2	TC1/4" IP	Track Clip 1/4" IP 1.940" L x 1" W	1

This Document Contains Proprietary Data that is property of Pendant Systems which reserves all rights to it. Unauthorized use without authorization is prohibited.

Pendant Systems
 1670 Winchester Rd.
 Bensalem, PA 19020
 P-215-638-8552
 F-215-638-8554
 www.PendantSystems.com

UNLESS OTHERWISE SPECIFIED DIMENSIONS ARE IN BOTH INCHES & MILLIMETERS UNLESS OTHERWISE NOTED TOLERANCES: LINEAR: XX= .02" XXX= \pm .010" ANGULAR: \pm 1 Degree		FINISH:		TITLE: Track Clip Kit Flush 1-4	
DO NOT SCALE DRAWING		MATERIAL:		Part #	
DEBUR AND BREAK SHARP EDGES				REVISION	
DRAWN DATE: 5/10/16		Drawn By: MWR		SCALE: NTS SHEET 2 OF 2	