

ITEM NO.	PART NUMBER	DESCRIPTION	QTY.
1	#243B RM	5" Round Canopy	1
2	#35	1/4" IP Tap Half Ball	1
3	MP Plate HB	Monopoint Plate for Half Ball for MP Crossbar 2.82" L x 1.650" W x .075" Material Thickness Half Ball Opening for #35, #34 and #147 Tapped 8/32" Hole Zinc Plated Steel	1
4	MP Swivel Clip	Mono Point Swivel Retaining Clip for MP-Plate HB Spring Steel	1
5	MP Crossbar Round	4.75" Round Crossbar .080" Material Thickness Zinc Plated Steel	1
6	#64	1/4" IP x 3/4" O.D. x 1/4" Thick Zinc Plated	2
7	#237	.875" Hole Bushing .945" W x .750" I.D. x .250" H .063" Max Panel Thickness	1
8	#32	8/32 Green Ground Screw	1
9	#183	8/32" x 1/4" Philip Head Ext Sems Steel Zinc Screw	1
10	MP Screws	6/32" x 3/4" Long Zinc Plated Flat Countersunk Head Machine Screw. Available with White, Black or Zinc Finished Heads	2

STEM LENGTH WILL VARY. ORDER SEPARATELY
MP SW1/4 RD USED WITH STEM 1/4" IP
1/4" IPS .500"-.510" O.D. 18 T.P.I.

*50° SWIVEL

This Document Contains Proprietary Data that is property of Pendant Systems which reserves all rights to it. Unauthorized use without authorization is prohibited.

Pendant Systems
 1670 Winchester Rd.
 Bensalem, PA 19020
 P-215-638-8552
 F-215-638-8554
 www.PendantSystems.com

UNLESS OTHERWISE SPECIFIED DIMENSIONS ARE IN BOTH INCHES & MILLIMETERS UNLESS OTHERWISE NOTED TOLERANCES: LINEAR: XX= .02" XXX= \pm .010" ANGULAR: \pm 1 Degree		FINISH:		TITLE: MP SW 1-4 RD	
DO NOT SCALE DRAWING		MATERIAL:		Part #	
DEBUR AND BREAK SHARP EDGES				REVISION	
DRAWN DATE: 3/4/16		Drawn By: MWR		SCALE: NTS SHEET 1 OF 2	

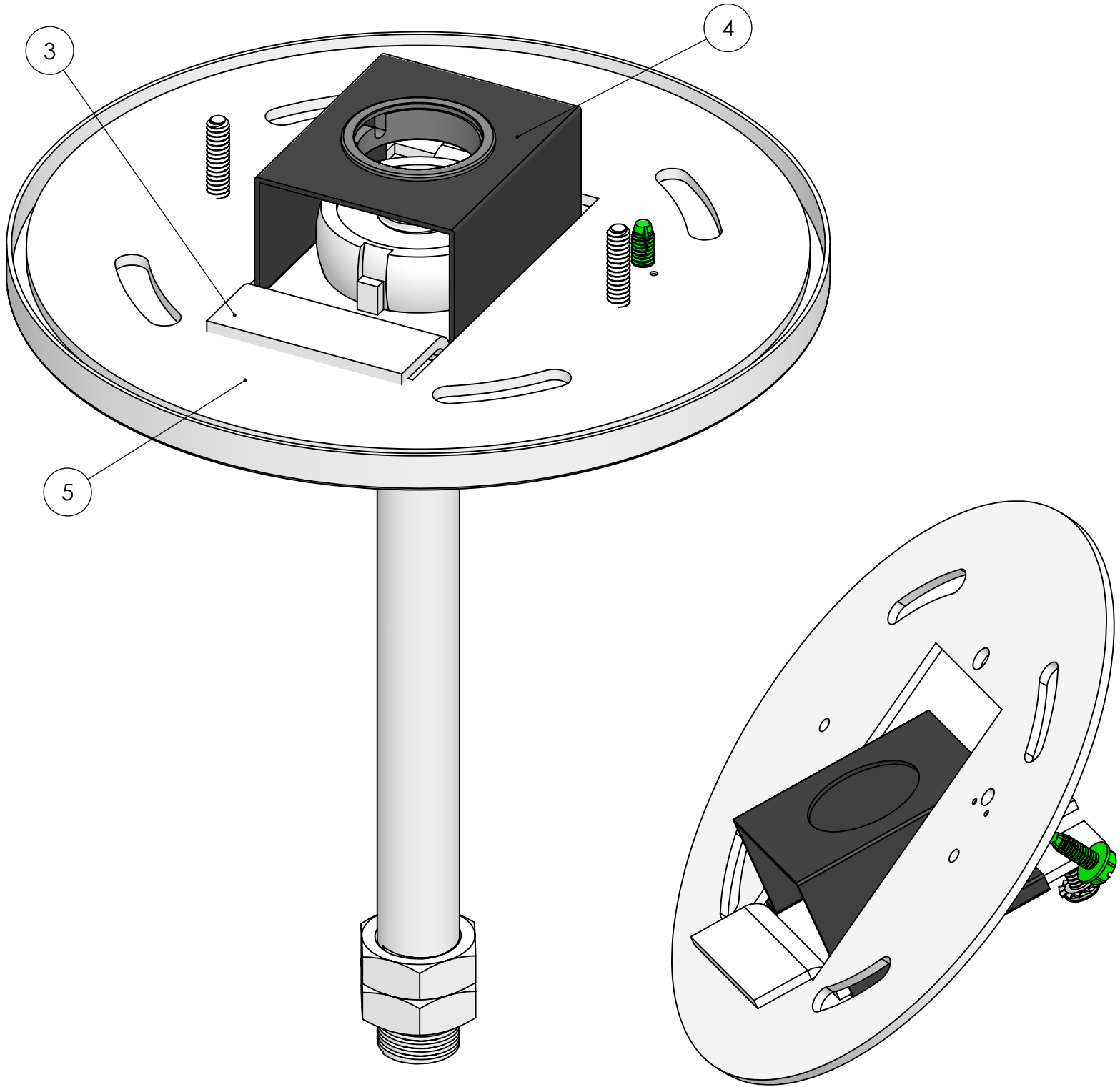

This Document
Contains Proprietary
Data that is property
of Pendant Systems
which reserves all
rights to it.
Unauthorized use
without authorization
is prohibited.

Pendant Systems
1670 Winchester Rd.
Bensalem, PA 19020
P-215-638-8552
F-215-638-8554
www.PendantSystems.com

UNLESS OTHERWISE SPECIFIED DIMENSIONS ARE IN INCHES & MILLIMETERS UNLESS OTHERWISE NOTED TOLERANCES:
LINEAR: XX= .02' XXX= $\pm .010$ " ANGULAR: ± 1 Degree

FINISH:
MATERIAL:

TITLE: MP SW 1/4 RD Assembled

DO NOT SCALE DRAWING
DEBUR AND BREAK SHARP EDGES

Part #

SCALE: NTS SHEET 2 OF 2 REVISION

DRAWN DATE: 3/4/16

Drawn By: MWR

SCALE: NTS SHEET 2 OF 2 REVISION