

**\*Reference Bill Of Materials on Page 3**

**STEM LENGTH WILL VARY. ORDER SEPARATELY  
MP-ST3/8 USED WITH STEM 3/8" IP  
3/8" IPS .625"-.635" O.D. 18 T.P.I.**

This Document Contains Proprietary Data that is property of Pendant Systems which reserves all rights to it. Unauthorized use without authorization is prohibited.

**Pendant Systems**  
1670 Winchester Rd.  
Bensalem, PA 19020  
P-215-638-8552  
F-215-638-8554  
[www.PendantSystems.com](http://www.PendantSystems.com)

UNLESS OTHERWISE SPECIFIED DIMENSIONS ARE IN BOTH INCHES & MILLIMETERS UNLESS OTHERWISE NOTED TOLERANCES: LINEAR: XX= .02" XXX= $\pm .010$ " ANGULAR: $\pm 1$ Degree		FINISH:	TITLE:  MP-ST3-8	
DO NOT SCALE DRAWING	MATERIAL:	Part #	REVISION	
DEBUR AND BREAK SHARP EDGES	Drawn By: MWR	SCALE: NTS	SHEET 1 OF 3	
DRAWN DATE: 5/18/16				

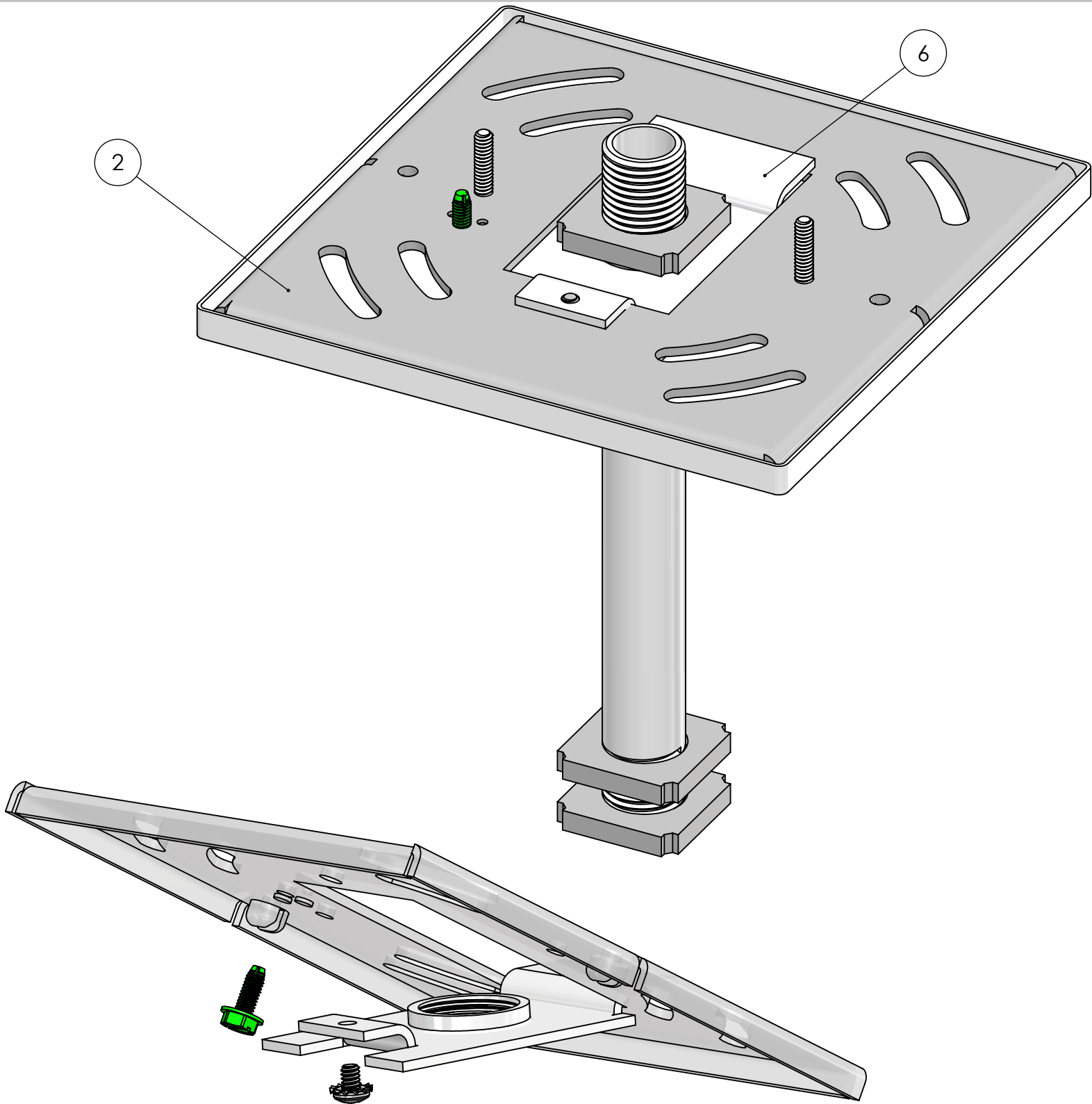

This Document  
Contains Proprietary  
Data that is property  
of Pendant Systems  
which reserves all  
rights to it.  
Unauthorized use  
without authorization  
is prohibited.

# Pendant Systems

1670 Winchester Rd.  
Bensalem, PA 19020  
P-215-638-8552  
F-215-638-8554  
[www.PendantSystems.com](http://www.PendantSystems.com)

UNLESS OTHERWISE SPECIFIED DIMENSIONS ARE IN BOTH INCHES & MILLIMETERS UNLESS OTHERWISE NOTED TOLERANCES:

LINEAR: XX= .02" XXX=  $\pm .010"$  ANGULAR:  $\pm 1$  Degree

FINISH:

MATERIAL:

TITLE:

MP-ST3-8 Assembled

Part #

DO NOT SCALE DRAWING

DEBUR AND BREAK SHARP EDGES

DRAWN DATE: 5/18/16

Drawn By: MWR

SCALE: NTS

SHEET 2 OF 3

REVISION

ITEM NO.	PART NUMBER	DESCRIPTION	QTY.
1	#241B SQ RM	Monopoint Canopy with 6/32" Mounting Holes & .675" Center Hole	1
2	MP Crossbar	Crossbar 14 Gauge Zinc Plated Steel 4.8" L x 4.8" W x .075" Material Thickness	1
3	#32	8/32 Green Ground Screw	1
4	#183	8/32" x 1/4" Philip Head Ext Sems Steel Zinc Screw	1
5	#22	3/8" IP x 1 1/16" Square x .073" Thick Zinc Plated	3
6	MP Plate 3-8 IP	3/8" IP Monopoint Plate for MP Crossbar 2.82" L x 1.650" W x .075" Material Thickness Tapped 8/32" Hole Zinc Plated Steel	1
7	MP Screws	6/32" x 3/4" Long Zinc Plated Flat Countersunk Head Machine Screw. Available with White, Black or Zinc Finished Heads	2

This Document  
Contains Proprietary  
Data that is property  
of Pendant Systems  
which reserves all  
rights to it.  
Unauthorized use  
without authorization  
is prohibited.

## Pendant Systems

1670 Winchester Rd.  
Bensalem, PA 19020  
P-215-638-8552  
F-215-638-8554  
[www.PendantSystems.com](http://www.PendantSystems.com)

UNLESS OTHERWISE SPECIFIED DIMENSIONS ARE IN BOTH INCHES & MILLIMETERS UNLESS OTHERWISE NOTED TOLERANCES:

LINEAR: XX= .02" XXX=  $\pm$ .010" ANGULAR:  $\pm$  1 Degree

FINISH:

TITLE:

Bill Of Materials

DO NOT SCALE DRAWING

MATERIAL:

Part #

DEBUR AND BREAK SHARP EDGES

REVISION

DRAWN DATE: 5/18/16

Drawn By: MWR

SCALE: NTS

SHEET 3 OF 3