

***Reference Bill of Materials on Page 3**

STEM LENGTH WILL VARY. ORDER SEPARATELY
 MP-SW3/8 MAG ADJ ID USED WITH STEM 3/8"
 IP I.D. PH
 3/8" IPS .625"-.635" O.D. 18 T.P.I
 Add Suffix WHT for White or Bk for Black

***45° SWIVEL**

This Document
 Contains Proprietary
 Data that is property
 of Pendant Systems
 which reserves all
 rights to it.
 Unauthorized use
 without authorization
 is prohibited.

Pendant Systems

1670 Winchester Rd.
 Bensalem, PA 19020
 P-215-638-8552
 F-215-638-8554
 www.PendantSystems.com

UNLESS OTHERWISE SPECIFIED DIMENSIONS ARE IN BOTH INCHES & MILLIMETERS UNLESS OTHERWISE NOTED TOLERANCES: LINEAR: XX= .02" XXX= \pm .010" ANGULAR: \pm 1 Degree		FINISH:		TITLE: MP-SW3-8 MAG ADJ ID	
DO NOT SCALE DRAWING		MATERIAL:		Part #	
DEBUR AND BREAK SHARP EDGES				REVISION	
DRAWN DATE: 4/5/17		Drawn By: MWR		SCALE: NTS	
				SHEET 1 OF 3	

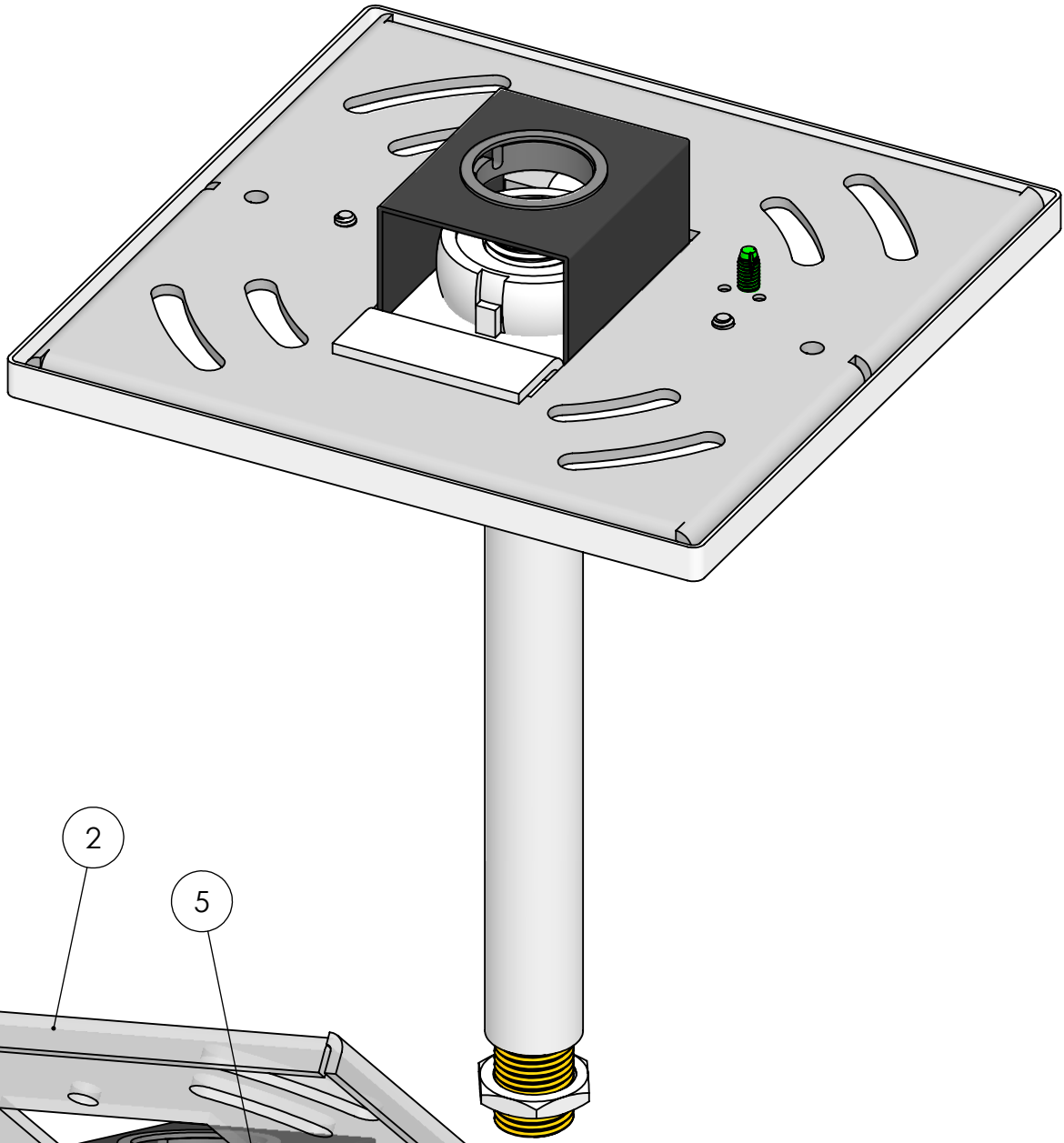

This Document
Contains Proprietary
Data that is property
of Pendant Systems
which reserves all
rights to it.
Unauthorized use
without authorization
is prohibited.

Pendant Systems
1670 Winchester Rd.
Bensalem, PA 19020
P-215-638-8552
F-215-638-8554
www.PendantSystems.com

UNLESS OTHERWISE SPECIFIED DIMENSIONS ARE IN BOTH INCHES & MILLIMETERS UNLESS OTHERWISE NOTED TOLERANCES:
LINEAR: XX= .02" XXX= $\pm .010"$ ANGULAR: ± 1 Degree

FINISH:
MATERIAL:

TITLE:
MP-SW3-8 MAG ADJ ID Assembled

DO NOT SCALE DRAWING
DEBUR AND BREAK SHARP EDGES

Part #

SCALE: NTS
SHEET 2 OF 3
REVISION

DRAWN DATE: 4/5/17

Drawn By: MWR

SCALE: NTS
SHEET 2 OF 3
REVISION

ITEM NO.	PART NUMBER	DESCRIPTION	QTY.
1	276B SQ	5" Canopy w/1.180" CH	1
2	MP Crossbar	Crossbar 14 Gauge Zinc Plated Steel 4.8" L x 4.8" W x .075" Material Thickness	1
3	#34ADJ	3/8" IP Slip Half Ball Bright Casting	1
4	MP Plate HB	Monopoint Plate for Half Ball for MP Crossbar 2.82" L x 1.650" W x .075" Material Thickness Half Ball Opening for #35,#34 and #147 Tapped 8/32" Hole Zinc Plated Steel	1
5	MP Swivel Clip	Mono Point Swivel Retaining Clip for MP-Plate HB Spring Steel	1
6	#237	.875" Hole Bushing .945" W x .750" I.D. x .250" H .063" Max Panel Thickness	1
7	Magnet	#6 & #8 Magnet	2
8	271	6/32" x 1/4" L Flat Head Philips Machine Screw	2
9	183	8/32" x 1/4" Philip Head Ext Sems Steel Zinc Screw	1
10	#ADJ-SS	1/4" -20 Short (.350" Long) Socket Set Screw w/.125" DIA Point & 1/8" Allen Hex Head Pin for ADJ Series Half Balls	1
11	#SSS	1/4" -20 Socket Set Screw w/.125 DIA & 1/8" Allen Hex Head Pin for ADJ Series Half Balls	1
12	49-1	1/4" IP Nipple 1" L	1
13	#25	1/4" IP x 11/16 O.D. x 1/8" Thick Zinc Plated	1
14	#32	8/32 Green Ground Screw	1

This Document Contains Proprietary Data that is property of Pendant Systems which reserves all rights to it. Unauthorized use without authorization is prohibited.

Pendant Systems

1670 Winchester Rd.
Bensalem, PA 19020
P-215-638-8552
F-215-638-8554
www.PendantSystems.com

UNLESS OTHERWISE SPECIFIED DIMENSIONS ARE IN BOTH INCHES & MILLIMETERS UNLESS OTHERWISE NOTED TOLERANCES:

LINEAR: XX= .02" XXX= \pm .010" ANGULAR: \pm 1 Degree

FINISH:

TITLE:

Bill of Materials

DO NOT SCALE DRAWING

MATERIAL:

Part #

DEBUR AND BREAK SHARP EDGES

REVISION

DRAWN DATE: 4/5/17

Drawn By: MWR

SCALE: NTS

SHEET 3 OF 3