

ITEM NO.	PART NUMBER	DESCRIPTION	QTY.
1	276	5" Round w/ 1.18" CH	1
2	MP Crossbar Round	4.75" Round Crossbar .080" Material Thickness Zinc Plated Steel	1
3	MP Swivel Clip	Mono Point Swivel Retaining Clip for MP-Plate HB Spring Steel	1
4	#237	.875" Hole Bushing .945" W x .750" I.D. x .250" H .063" Max Panel Thickness	1
5	MP Plate HB	Monopoint Plate for Half Ball for MP Crossbar 2.82" L x 1.650" W x .075" Material Thickness Half Ball Opening for #35, #34 and #147 Tapped 8/32" Hole Zinc Plated Steel	1
6	Magnet	#6 & #8 Magnet	2
7	271	6/32" x 1/4" L Flat Head Philips Machine Screw	2
8	#34ADJ	3/8" IP Slip Half Ball Bright Casting	1
9	183	8/32" x 1/4" Philip Head Ext Sems Steel Zinc Screw	1
10	#32	8/32 Green Ground Screw	1
11	#ADJ-SS	1/4" -20 Short (.350" Long) Socket Set Screw w/.125" DIA Point & 1/8" Allen Hex Head Pin for ADJ Series Half Balls	1
12	#SSS	1/4" -20 Socket Set Screw w/.125 DIA & 1/8" Allen Hex Head Pin for ADJ Series Half Balls	1
13	#22	3/8" IP x 1 1/16" Square x .073" Thick Zinc Plated	2

**STEM LENGTH WILL VARY. ORDER SEPARATELY
MP SW3/8 RD MAG ADJ USED WITH STEM 3/8" IP
O.D. PH
3/8" IPS .625"-.635" O.D. 18 T.P.I.**

***45° SWIVEL**

This Document
Contains Proprietary
Data that is property
of Pendant Systems
which reserves all
rights to it.
Unauthorized use
without authorization
is prohibited.

Pendant Systems

1670 Winchester Rd.
Bensalem, PA 19020
P-215-638-8552
F-215-638-8554
www.PendantSystems.com

UNLESS OTHERWISE SPECIFIED DIMENSIONS ARE IN BOTH INCHES & MILLIMETERS UNLESS OTHERWISE NOTED TOLERANCES:

LINEAR: XX= .02" XXX= \pm .010" ANGULAR: \pm 1 Degree

DO NOT SCALE DRAWING

DEBUR AND BREAK SHARP EDGES

DRAWN DATE: 11/18/16

FINISH:

MATERIAL:

Drawn By: MWR

TITLE:

MP SW 3-8 RD MAG ADJ

Part #

SCALE: NTS

SHEET 1 OF 2

REVISION

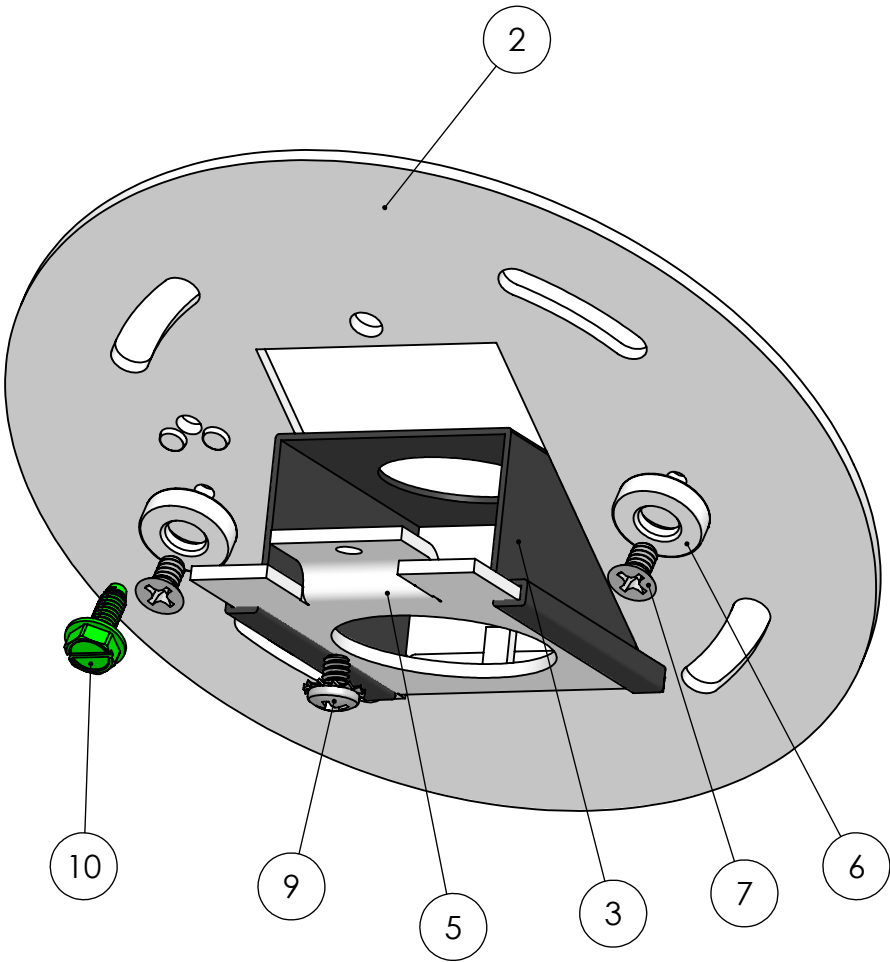
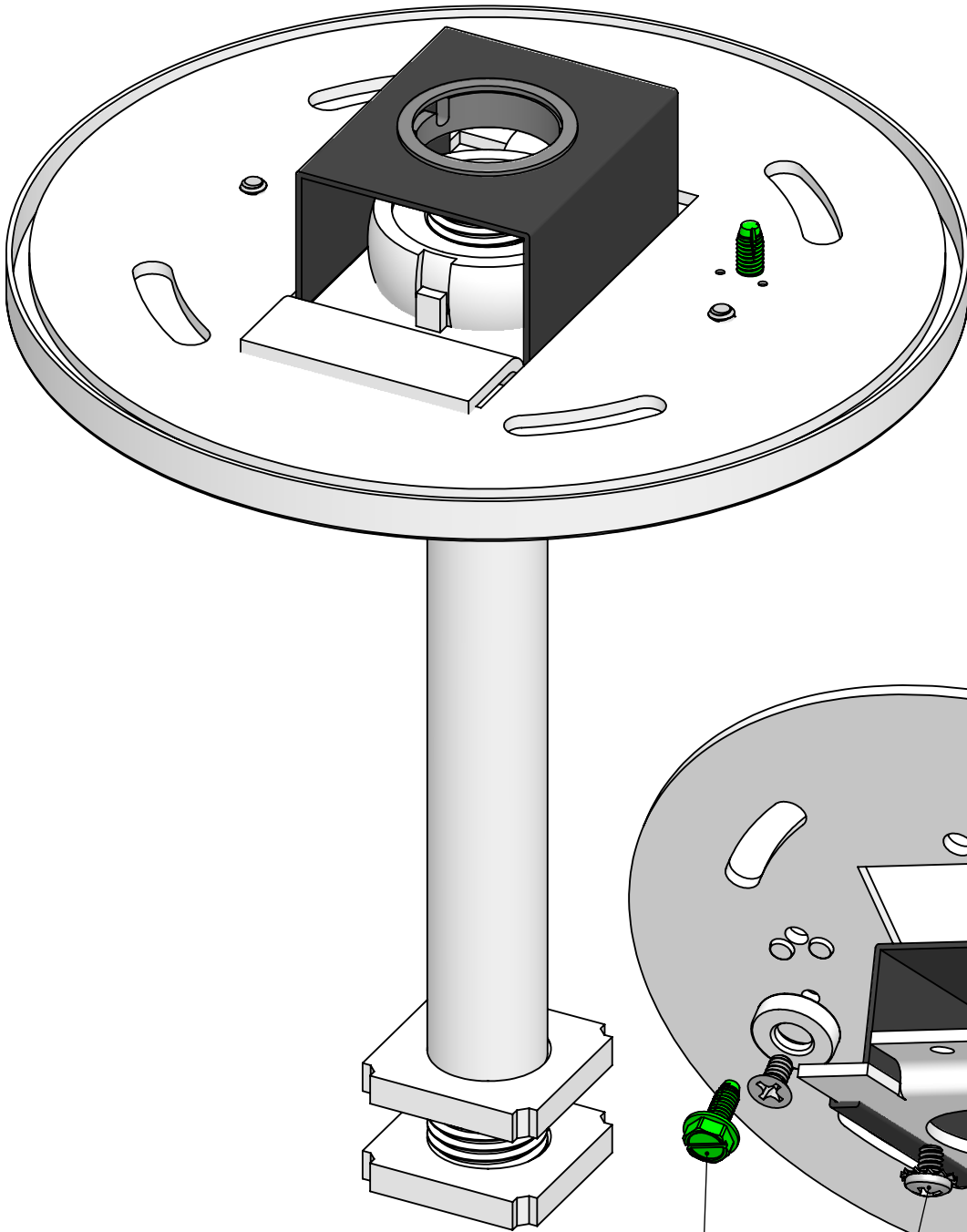

This Document
Contains Proprietary
Data that is property
of Pendant Systems
which reserves all
rights to it.
Unauthorized use
without authorization
is prohibited.

Pendant Systems
1670 Winchester Rd.
Bensalem, PA 19020
P-215-638-8552
F-215-638-8554
www.PendantSystems.com

UNLESS OTHERWISE SPECIFIED DIMENSIONS ARE IN BOTH INCHES & MILLIMETERS UNLESS OTHERWISE NOTED TOLERANCES:
LINEAR: XX= .02" XXX= \pm .010" ANGULAR: \pm 1 Degree

FINISH:
MATERIAL:

TITLE:
MP SW 3-8 RD MAG ADJ Assembled

DO NOT SCALE DRAWING
DEBUR AND BREAK SHARP EDGES

Part #

SCALE: NTS
SHEET 2 OF 2
REVISION

DRAWN DATE: 11/18/16

Drawn By: MWR

SCALE: NTS
SHEET 2 OF 2
REVISION