

ITEM NO.	PART NUMBER	DESCRIPTION	QTY.
1	#243B RM	5" Round	1
2	#ADJ-SS	1/4" -20 Short (.350" Long) Socket Set Screw w/.125" DIA Point & 1/8" Allen Hex Head Pin for ADJ Series Half Balls	1
3	#SSS	1/4" -20 Socket Set Screw w/.125 DIA & 1/8" Allen Hex Head Pin for ADJ Series Half Balls	1
4	MP Plate HB	Monopoint Plate for Half Ball for MP Crossbar 2.82" L x 1.650" W x .075" Material Thickness Half Ball Opening for #35, #34 and #147 Tapped 8/32" Hole Zinc Plated Steel	1
5	MP Crossbar Round	4.75" Round Crossbar .080" Material Thickness Zinc Plated Steel	1
6	MP Swivel Clip	Mono Point Swivel Retaining Clip for MP-Plate HB Spring Steel	1
7	MP Screws	6/32" x 3/4" Long Zinc Plated Flat Countersunk Head Machine Screw. Available with White, Black or Zinc Finished Heads	2
8	#34ADJ	3/8" IP Slip Half Ball Bright Casting	1
9	#22	3/8" IP x 1 1/16" Square x .073" Thick Zinc Plated	2
10	#32	8/32 Green Ground Screw	1
11	#183	8/32" x 1/4" Philip Head Ext Sems Steel Zinc Screw	1
12	#237	.875" Hole Bushing .945" W x .750" I.D. x .250" H .063" Max Panel Thickness	1

**STEM LENGTH WILL VARY. ORDER SEPARATELY
MP SW3/8 RD ADJ USED WITH STEM 3/8" IP
O.D. PH
3/8" IPS .625"-.635" O.D. 18 T.P.I.**

This Document Contains Proprietary Data that is property of Pendant Systems which reserves all rights to it. Unauthorized use without authorization is prohibited.

Pendant Systems
1670 Winchester Rd.
Bensalem, PA 19020
P-215-638-8552
F-215-638-8554
www.PendantSystems.com

UNLESS OTHERWISE SPECIFIED DIMENSIONS ARE IN BOTH INCHES & MILLIMETERS UNLESS OTHERWISE NOTED TOLERANCES: LINEAR: XX= .02" XXX= -.010" ANGULAR: ± 1 Degree		FINISH:	TITLE: MP SW 3-8 RD ADJ
DO NOT SCALE DRAWING	MATERIAL:	Part #	REVISION
DEBUR AND BREAK SHARP EDGES	Drawn By: MWR	SCALE: NTS	SHEET 1 OF 2
DRAWN DATE: 3/7/16			

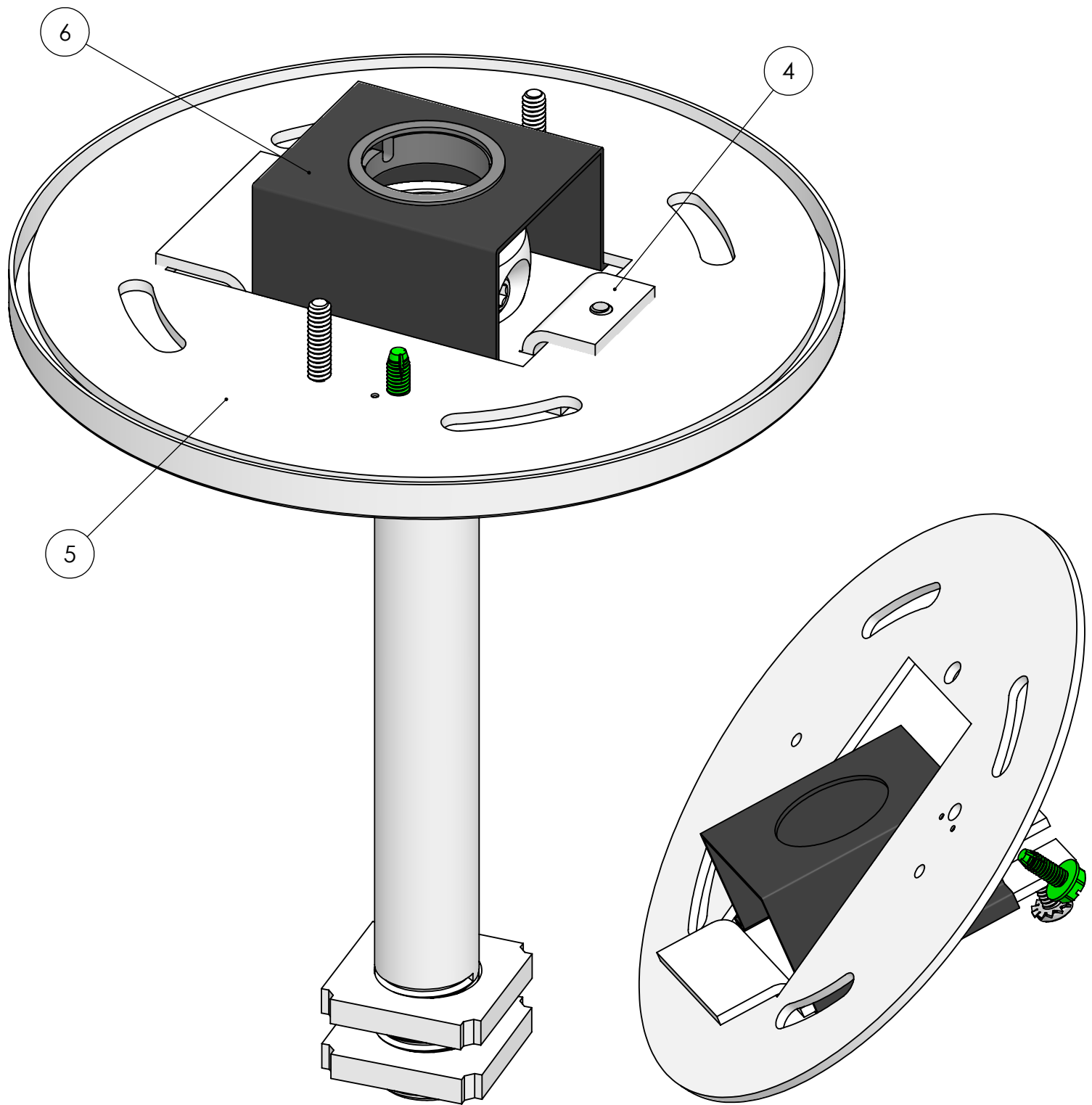

This Document
Contains Proprietary
Data that is property
of Pendant Systems
which reserves all
rights to it.
Unauthorized use
without authorization
is prohibited.

Pendant Systems

1670 Winchester Rd.
Bensalem, PA 19020
P-215-638-8552
F-215-638-8554
www.PendantSystems.com

UNLESS OTHERWISE SPECIFIED DIMENSIONS ARE IN INCHES & MILLIMETERS UNLESS OTHERWISE NOTED TOLERANCES:

LINEAR: XX= .02' XXX= $\pm .010$ " ANGULAR: ± 1 Degree

FINISH:

TITLE:

MP SW 3/8 RD ADJ Assembled

DO NOT SCALE DRAWING

MATERIAL:

Part #

DEBUR AND BREAK SHARP EDGES

REVISION

DRAWN DATE: 3/7/16

Drawn By: MWR

SCALE: NTS

SHEET 2 OF 2