

ITEM NO.	PART NUMBER	DESCRIPTION	QTY.
1	276	5" Round w/ 1.18" CH	1
2	MP Crossbar Round	4.75" Round Crossbar .080" Material Thickness Zinc Plated Steel	1
3	MP Swivel Clip	Mono Point Swivel Retaining Clip for MP-Plate HB Spring Steel	1
4	#237	.875" Hole Bushing .945" W x .750" I.D. x .250" H .063" Max Panel Thickness	1
5	MP Plate HB	Monopoint Plate for Half Ball for MP Crossbar 2.82" L x 1.650" W x .075" Material Thickness Half Ball Opening for #35, #34 and #147 Tapped 8/32" Hole Zinc Plated Steel	1
6	Magnet	#6 & #8 Magnet	2
7	271	6/32" x 1/4" L Flat Head Philips Machine Screw	2
8	#35ADJ	1/4" IP Slip Half Ball Bright Casting	1
9	183	8/32" x 1/4" Philip Head Ext Sems Steel Zinc Screw	1
10	#32	8/32 Green Ground Screw	1
11	#ADJ-SS	1/4" -20 Short (.350" Long) Socket Set Screw w/.125" DIA Point & 1/8" Allen Hex Head Pin for ADJ Series Half Balls	1
12	#SSS	1/4" -20 Socket Set Screw w/.125 DIA & 1/8" Allen Hex Head Pin for ADJ Series Half Balls	1
13	#64	1/4" IP x 3/4 O.D. x 1/4" Thick Zinc Plated	2
14	ADJ Tool Kit	Drill Bit 1/8" & Allen Wrench 1/8"	1

**STEM LENGTH WILL VARY. ORDER SEPARATELY  
MP SW1/4 MAG ADJ TK USED WITH STEM 1/4" IP  
O.D. PH  
1/4" IPS .500"-.510" O.D. 18 T.P.I.  
Add Suffix WHT for White or Bk for Black**

This Document Contains Proprietary Data that is property of Pendant Systems which reserves all rights to it. Unauthorized use without authorization is prohibited.

## Pendant Systems

1670 Winchester Rd.  
Bensalem, PA 19020  
P-215-638-8552  
F-215-638-8554  
[www.PendantSystems.com](http://www.PendantSystems.com)

UNLESS OTHERWISE SPECIFIED DIMENSIONS ARE IN BOTH INCHES & MILLIMETERS UNLESS OTHERWISE NOTED TOLERANCES:

LINEAR: XX= .02" XXX=  $\pm .010"$  ANGULAR:  $\pm 1$  Degree

FINISH:

TITLE:

MP SW 1-4 RD MAG ADJ TK

DO NOT SCALE DRAWING

MATERIAL:

Part #

DEBUR AND BREAK SHARP EDGES

REVISION

DRAWN DATE: 11/18/16

Drawn By: MWR

SCALE: NTS

SHEET 1 OF 2

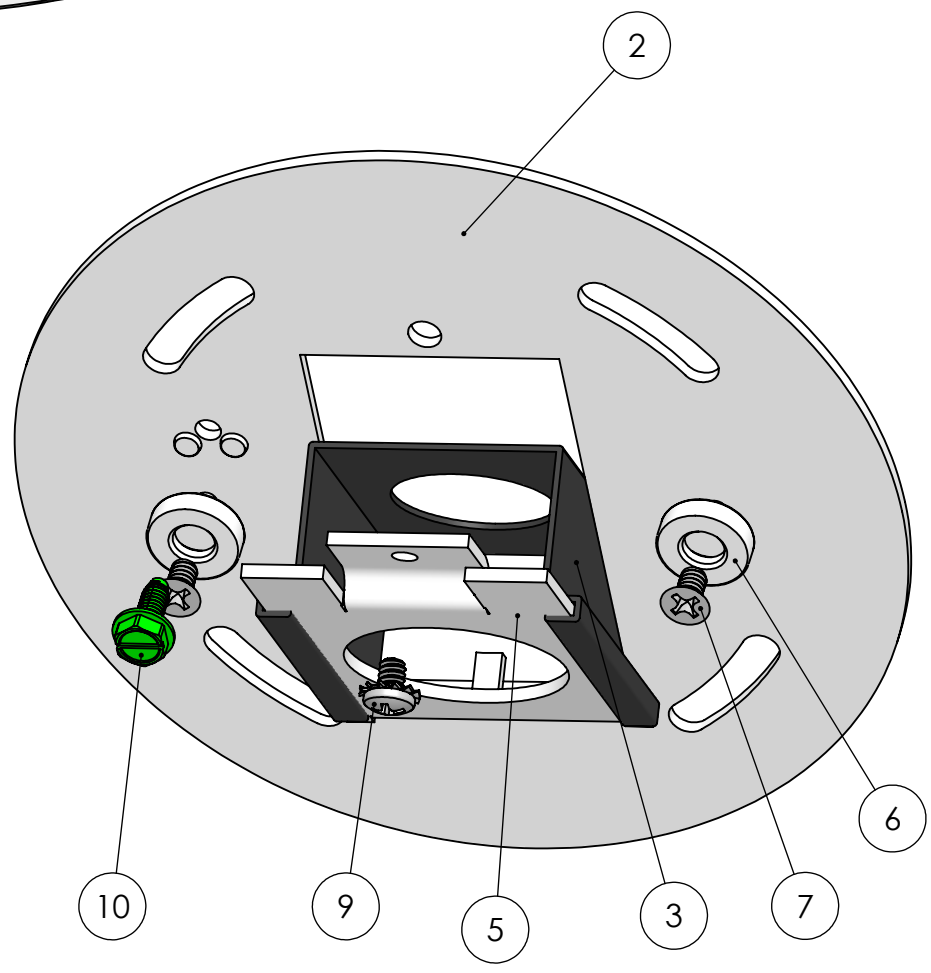
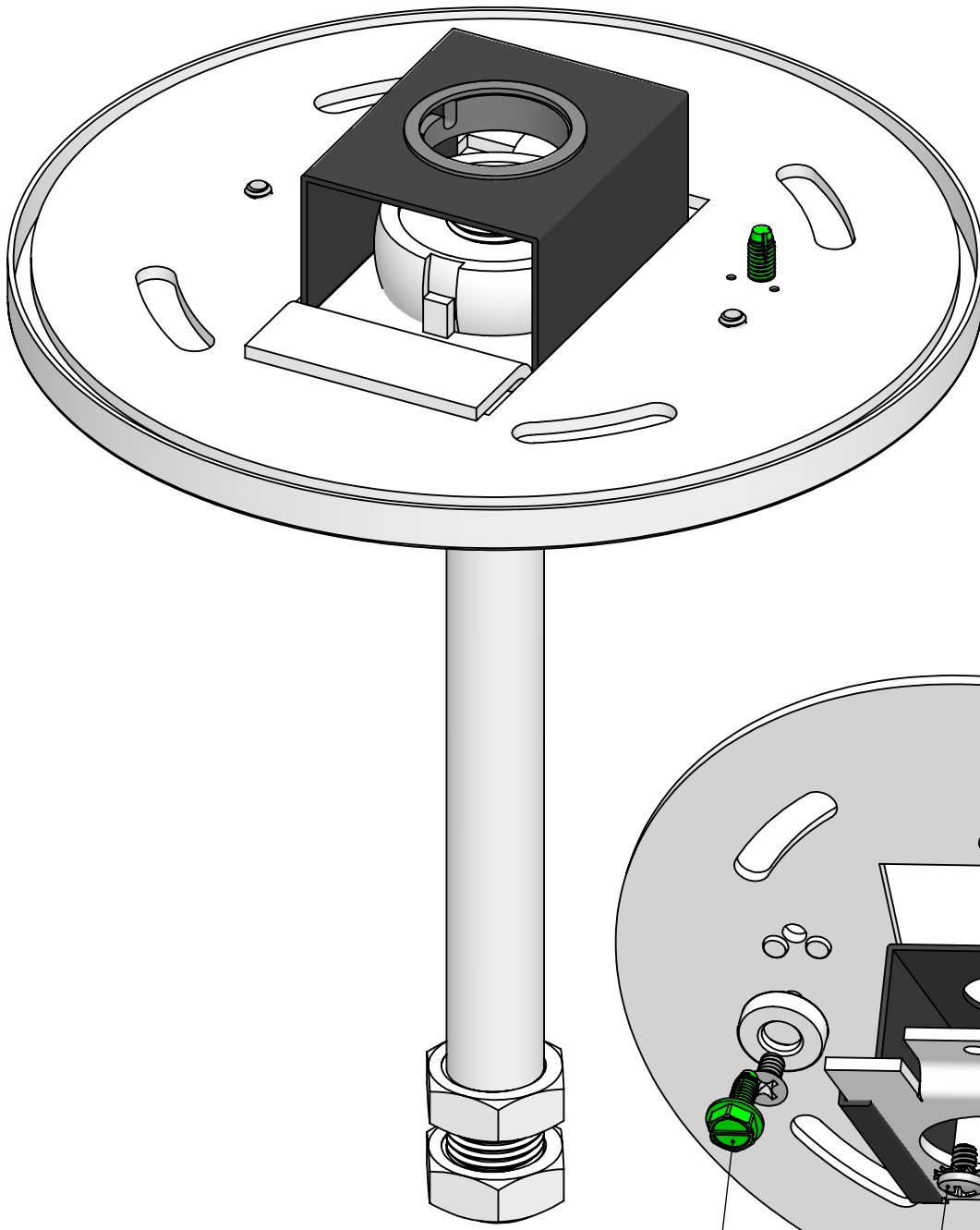

This Document  
Contains Proprietary  
Data that is property  
of Pendant Systems  
which reserves all  
rights to it.  
Unauthorized use  
without authorization  
is prohibited.

**Pendant Systems**  
1670 Winchester Rd.  
Bensalem, PA 19020  
P-215-638-8552  
F-215-638-8554  
[www.PendantSystems.com](http://www.PendantSystems.com)

UNLESS OTHERWISE SPECIFIED DIMENSIONS ARE IN BOTH INCHES & MILLIMETERS UNLESS OTHERWISE NOTED TOLERANCES:  
LINEAR: XX= .02" XXX=  $\pm$ .010" ANGULAR:  $\pm$  1 Degree

FINISH:  
MATERIAL:

TITLE:  
MP SW 1-4 RD MAG ADJ Assembled

DO NOT SCALE DRAWING  
DEBUR AND BREAK SHARP EDGES

Part #

SCALE: NTS

SHEET 2 OF 2

REVISION

DRAWN DATE: 11/18/16

Drawn By: MWR

SCALE: NTS

SHEET 2 OF 2

REVISION