

ITEM NO.	PART NUMBER	DESCRIPTION	QTY.
1	#243B RM	5" Round	1
2	#35ADJ	1/4" IP Slip Half Ball Bright Casting	1
3	#64	1/4" IP x 3/4 O.D. x 1/4" Thick Zinc Plated	2
4	#ADJ-SS	1/4" -20 Short (.350" Long) Socket Set Screw w/.125" DIA Point & 1/8" Allen Hex Head Pin for ADJ Series Half Balls	1
5	#SSS	1/4" -20 Socket Set Screw w/.125 DIA & 1/8" Allen Hex Head Pin for ADJ Series Half Balls	1
6	MP Plate HB	Monopoint Plate for Half Ball for MP Crossbar 2.82" L x 1.650" W x .075" Material Thickness Half Ball Opening for #35, #34 and #147 Tapped 8/32" Hole Zinc Plated Steel	1
7	MP Swivel Clip	Mono Point Swivel Retaining Clip for MP-Plate HB Spring Steel	1
8	MP Screws	6/32" x 3/4" Long Zinc Plated Flat Countersunk Head Machine Screw. Available with White, Black or Zinc Finished Heads	2
9	ADJ Tool Kit	Drill Bit 1/8" & Allen Wrench 1/8"	1
10	#32	8/32 Green Ground Screw	1
11	#183	8/32" x 1/4" Philip Head Ext Sems Steel Zinc Screw	1
12	MP Crossbar Round	4.75" Round Crossbar .080" Material Thickness Zinc Plated Steel	1
13	#237	.875" Hole Bushing .945" W x .750" I.D. x .250" H .063" Max Panel Thickness	1

**STEM LENGTH WILL VARY. ORDER SEPARATELY  
MP SW 1/4 RD ADJ TK USED WITH STEM 1/4" IP  
O.D. PH  
1/4" IPS .500"-.510" O.D. 18 T.P.I.**

**\*50° SWIVEL**

This Document Contains Proprietary Data that is property of Pendant Systems which reserves all rights to it. Unauthorized use without authorization is prohibited.

**Pendant Systems**  
1670 Winchester Rd.  
Bensalem, PA 19020  
P-215-638-8552  
F-215-638-8554  
[www.PendantSystems.com](http://www.PendantSystems.com)

UNLESS OTHERWISE SPECIFIED DIMENSIONS ARE IN BOTH INCHES & MILLIMETERS UNLESS OTHERWISE NOTED TOLERANCES: LINEAR: XX= .02" XXX= ±.010" ANGULAR: ± 1 Degree	FINISH:	TITLE: <b>MP SW 1-4 RD ADJ TK</b>
DO NOT SCALE DRAWING	MATERIAL:	Part #
DEBUR AND BREAK SHARP EDGES		SCALE: NTS
DRAWN DATE: 3/7/16	Drawn By: MWR	SHEET 1 OF 2
		REVISION

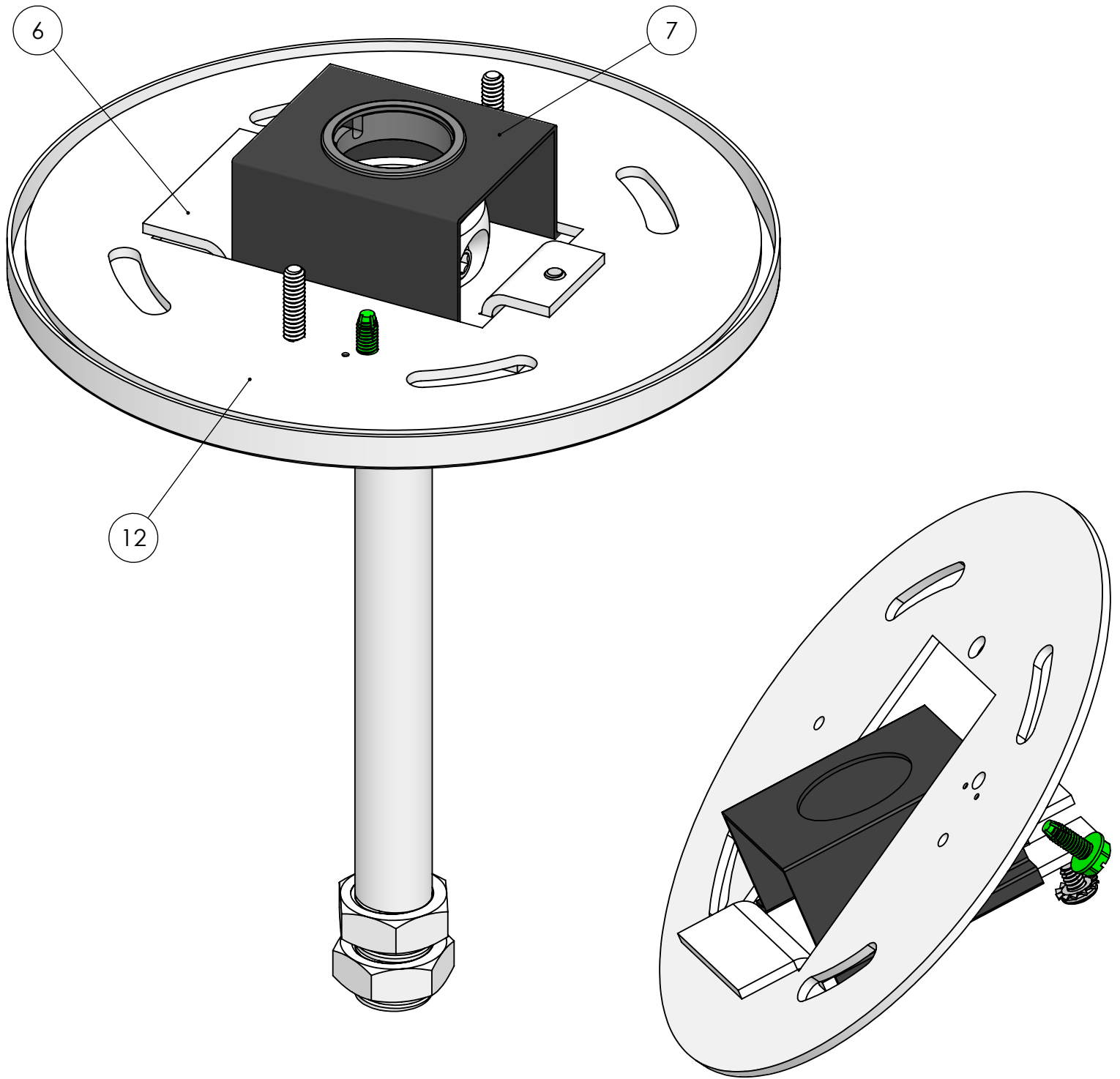

This Document  
Contains Proprietary  
Data that is property  
of Pendant Systems  
which reserves all  
rights to it.  
Unauthorized use  
without authorization  
is prohibited.

# Pendant Systems

1670 Winchester Rd.  
Bensalem, PA 19020  
P-215-638-8552  
F-215-638-8554  
[www.PendantSystems.com](http://www.PendantSystems.com)

UNLESS OTHERWISE SPECIFIED DIMENSIONS ARE IN INCHES & MILLIMETERS UNLESS OTHERWISE NOTED TOLERANCES:

LINEAR: XX= .02' XXX=  $\pm .010$ " ANGULAR:  $\pm 1$  Degree

FINISH:

TITLE:

MP SW 1/4 RD ADJ TK Assembled

DO NOT SCALE DRAWING

MATERIAL:

Part #

DEBUR AND BREAK SHARP EDGES

REVISION

DRAWN DATE: 3/7/16

Drawn By: MWR

SCALE: NTS

SHEET 2 OF 2