

**\*Reference Bill of Materials on Page 3**

STEM LENGTH WILL VARY. ORDER SEPARATELY  
 MP-ST1/4 ID USED WITH STEM 1/4" IP O.D.-I.D.  
 1/4" IPS .500"-.510" O.D. 18 T.P.I

This Document  
 Contains Proprietary  
 Data that is property  
 of Pendant Systems  
 which reserves all  
 rights to it.  
 Unauthorized use  
 without authorization  
 is prohibited.

**Pendant Systems**

1670 Winchester Rd.  
 Bensalem, PA 19020  
 P-215-638-8552  
 F-215-638-8554  
 www.PendantSystems.com

UNLESS OTHERWISE SPECIFIED DIMENSIONS ARE IN BOTH INCHES &  
 MILLIMETERS UNLESS OTHERWISE NOTED TOLERANCES:

LINEAR: XX= .02" XXX=  $\pm .010$ " ANGULAR:  $\pm 1$  Degree

FINISH:

TITLE:

MP-ST1-4 ID

DO NOT SCALE DRAWING

MATERIAL:

Part #

DEBUR AND BREAK SHARP EDGES

REVISION

DRAWN DATE: 5/15/17

Drawn By: MWR

SCALE: NTS

SHEET 1 OF 3

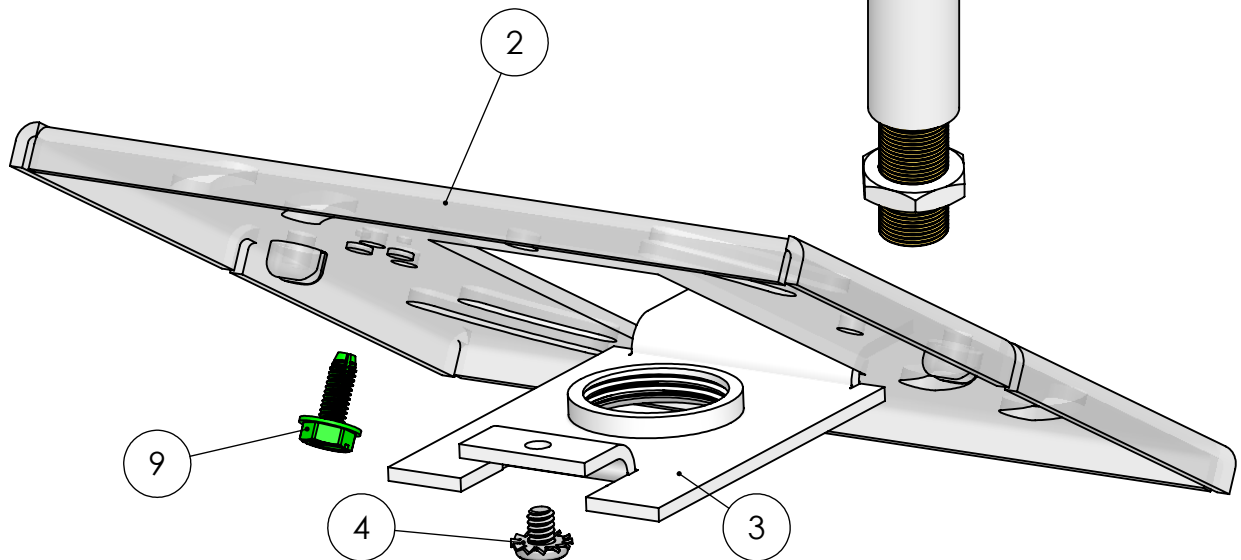
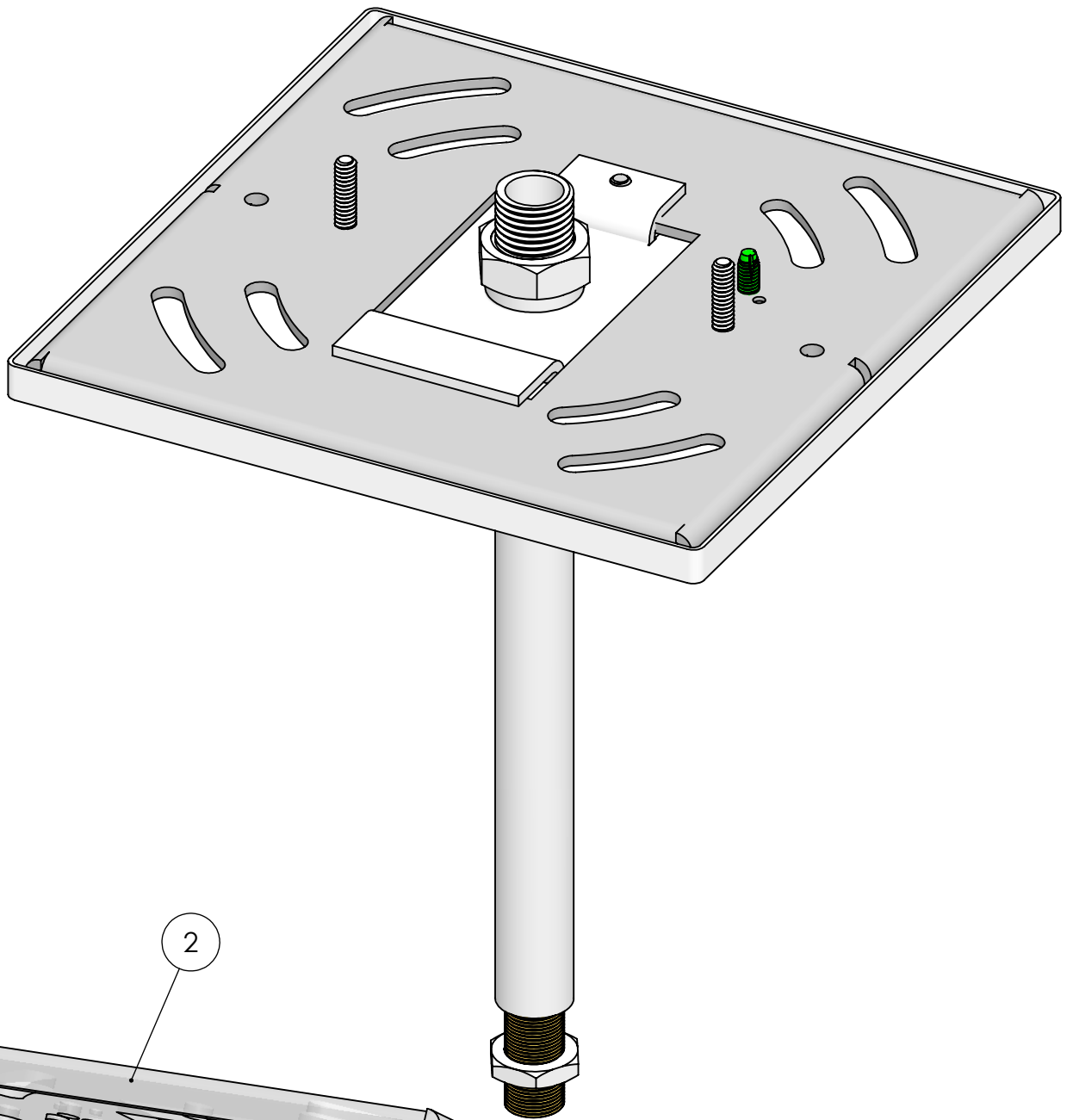

This Document  
Contains Proprietary  
Data that is property  
of Pendant Systems  
which reserves all  
rights to it.  
Unauthorized use  
without authorization  
is prohibited.

**Pendant Systems**  
1670 Winchester Rd.  
Bensalem, PA 19020  
P-215-638-8552  
F-215-638-8554  
[www.PendantSystems.com](http://www.PendantSystems.com)

UNLESS OTHERWISE SPECIFIED DIMENSIONS ARE IN BOTH INCHES & MILLIMETERS UNLESS OTHERWISE NOTED TOLERANCES:  
LINEAR: XX= .02" XXX=  $\pm .010"$  ANGULAR:  $\pm 1$  Degree

FINISH:  
MATERIAL:

TITLE: MP-ST1-4 ID Assembled

DO NOT SCALE DRAWING  
DEBUR AND BREAK SHARP EDGES

Part #

SCALE: NTS

SHEET 2 OF 3  
REVISION

DRAWN DATE: 5/15/17

Drawn By: MWR

SCALE: NTS

SHEET 2 OF 3

ITEM NO.	PART NUMBER	DESCRIPTION	QTY.
1	#240B SQ RM	Monopoint Canopy with 6/32" Mounting Holes & .575" Center Hole	1
2	MP Crossbar	Crossbar 14 Gauge Zinc Plated Steel 4.8" L x 4.8" W x .075" Material Thickness	1
3	MP Plate 1-4 IP	1/4" IP Monopoint Plate for MP Crossbar 2.82" L x 1.650" W x .075" Material Thickness Tapped 8/32" Hole Zinc Plated Steel	1
4	183	8/32" x 1/4" Philip Head Ext Sems Steel Zinc Screw	1
5	#64	1/4" IP x 3/4 O.D. x 1/4" Thick Zinc Plated	1
6	#60-1	1/8" IP Nipple 1" L	1
7	#133	1/8" IP x 9/16" O.D. x 1/8" Thick Zinc Plated	1
8	MP Screws	6/32" x 3/4" Long Zinc Plated Flat Countersunk Head Machine Screw. Available with White, Black or Zinc Finished Heads	2
9	#32	8/32 Green Ground Screw	1

This Document  
Contains Proprietary  
Data that is property  
of Pendant Systems  
which reserves all  
rights to it.  
Unauthorized use  
without authorization  
is prohibited.

## Pendant Systems

1670 Winchester Rd.  
Bensalem, PA 19020  
P-215-638-8552  
F-215-638-8554  
[www.PendantSystems.com](http://www.PendantSystems.com)

UNLESS OTHERWISE SPECIFIED DIMENSIONS ARE IN BOTH INCHES & MILLIMETERS UNLESS OTHERWISE NOTED TOLERANCES:

LINEAR: XX= .02" XXX=  $\pm$ .010" ANGULAR:  $\pm$  1 Degree

FINISH:

TITLE:

Bill of Materials

DO NOT SCALE DRAWING

MATERIAL:

Part #

DEBUR AND BREAK SHARP EDGES

REVISION

DRAWN DATE: 5/15/17

Drawn By: MWR

SCALE: NTS

SHEET 3 OF 3