

**\*Reference Bill Of Materials on Page 3**

**STEM LENGTH WILL VARY. ORDER SEPARATELY  
 MP15-[XX]-16 36PD ST1-4 USED WITH STEM  
 1/4" IP  
 1/4" IPS .500"-.510" O.D. 18 T.P.I.**

This Document Contains Proprietary Data that is property of Pendant Systems which reserves all rights to it. Unauthorized use without authorization is prohibited.

**Pendant Systems**  
 1670 Winchester Rd.  
 Bensalem, PA 19020  
 P-215-638-8552  
 F-215-638-8554  
 www.PendantSystems.com

UNLESS OTHERWISE SPECIFIED DIMENSIONS ARE IN BOTH INCHES & MILLIMETERS UNLESS OTHERWISE NOTED TOLERANCES: LINEAR: XX= .02" XXX= $\pm .010"$ ANGULAR: $\pm 1$ Degree		FINISH:		TITLE: MP15-[XX]-16 36PD ST1-4	
DO NOT SCALE DRAWING		MATERIAL:		Part #	
DEBUR AND BREAK SHARP EDGES				SCALE: NTS	
DRAWN DATE: 7/13/16		Drawn By: MWR		SHEET 1 OF 3	
				REVISION	

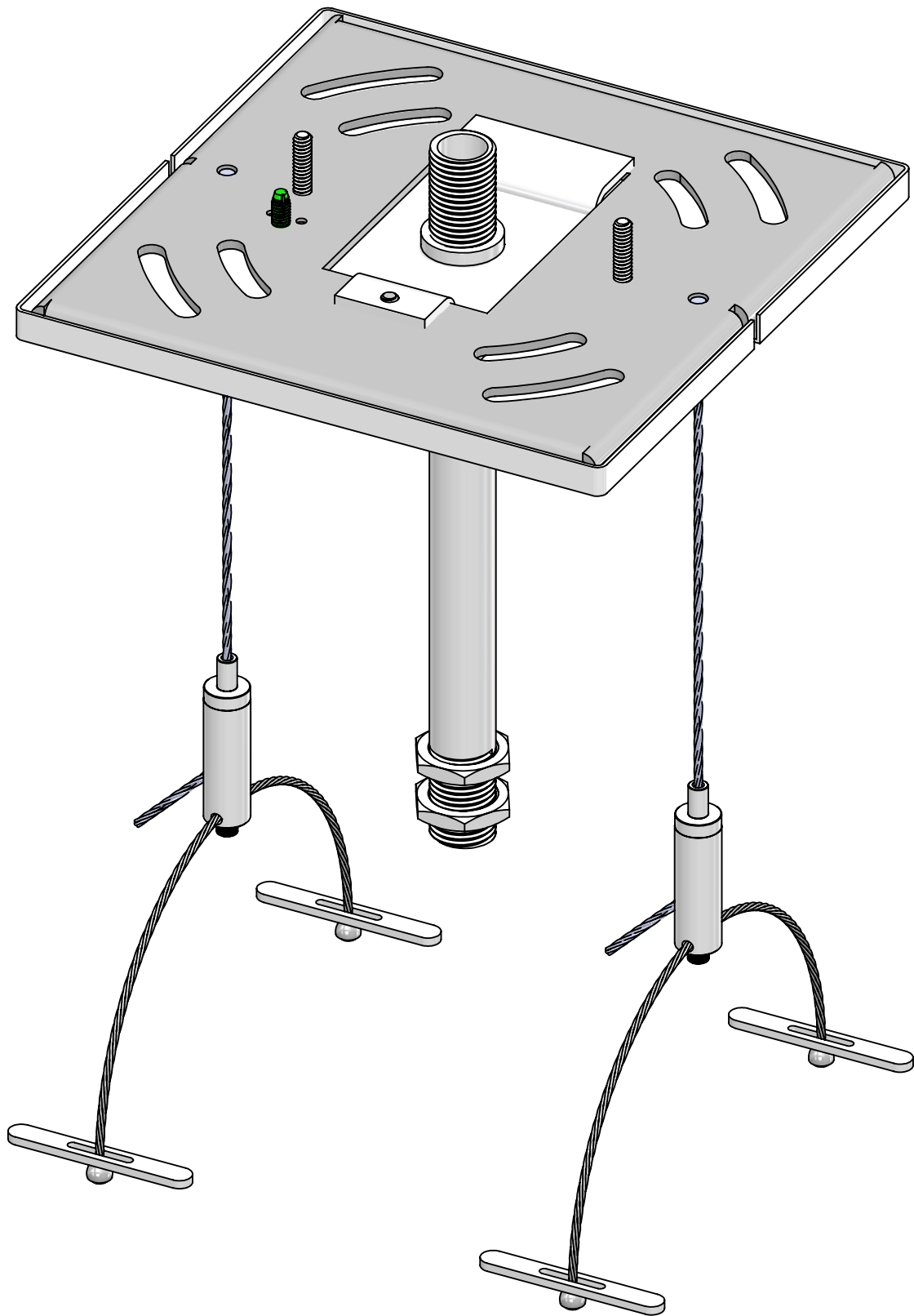

This Document  
Contains Proprietary  
Data that is property  
of Pendant Systems  
which reserves all  
rights to it.  
Unauthorized use  
without authorization  
is prohibited.

# Pendant Systems

1670 Winchester Rd.  
Bensalem, PA 19020  
P-215-638-8552  
F-215-638-8554  
[www.PendantSystems.com](http://www.PendantSystems.com)

UNLESS OTHERWISE SPECIFIED DIMENSIONS ARE IN INCHES & MILLIMETERS UNLESS OTHERWISE NOTED TOLERANCES:

LINEAR: XX= .02" XXX=  $\pm .010$ " ANGULAR:  $\pm 1$  Degree

FINISH:

TITLE:

MP15-[XX]-16 36PD ST1-4 Assembled

DO NOT SCALE DRAWING

MATERIAL:

Part #

DEBUR AND BREAK SHARP EDGES

REVISION

DRAWN DATE: 7/13/16

Drawn By: MWR

SCALE:1:1

SHEET 2 OF 3

ITEM NO.	PART NUMBER	DESCRIPTION	QTY.
1	MP Crossbar	Crossbar 14 Gauge Zinc Plated Steel 4.8" L x 4.8" W x .075" Material Thickness	1
2	#32	8/32 Green Ground Screw	1
3	MP Screws	6/32" x 3/4" Long Zinc Plated Flat Countersunk Head Machine Screw. Available with White, Black or Zinc Finished Heads	2
4	AC1-16-[XX]G HB	1/16" Cable w/60" HB End 1/16" Galvanized Cable Fuse Cut with Die Cast #2 Half Ball Stop Available in 24", 36", 60", 120", 180", & 240" Lengths 7x7 Cable	2
5	#242B SQ SL RH WHT	Monopoint Canopy w/Cable Slots and 6/32" Mounting Hole & Raw Mounts. .875 Center Hole	1
6	183	8/32" x 1/4" Philip Head Ext Sems Steel Zinc Screw	1
7	MP Plate 1-4 IP	1/4" IP Monopoint Plate for MP Crossbar 2.82" L x 1.650" W x .075" Material Thickness Tapped 8/32" Hole Zinc Plated Steel	1
8	#25	1/4" IP x 11/16 O.D. x 1/8" Thick Zinc Plated	2
9	MGR-SE-TH w/36CAB PD	Side Exit Gripper w/Through Hole for Crosscable for 1/16" Cable. Allen Set Screw on Bottom. 1.395" H x .354" W	2

This Document Contains Proprietary Data that is property of Pendant Systems which reserves all rights to it. Unauthorized use without authorization is prohibited.

## Pendant Systems

1670 Winchester Rd.  
Bensalem, PA 19020  
P-215-638-8552  
F-215-638-8554  
[www.PendantSystems.com](http://www.PendantSystems.com)

UNLESS OTHERWISE SPECIFIED DIMENSIONS ARE IN INCHES & MILLIMETERS UNLESS OTHERWISE NOTED TOLERANCES:

LINEAR: XX= .02" XXX=  $\pm$ .010" ANGULAR:  $\pm$  1 Degree

FINISH:

TITLE:

Bill Of Materials

DO NOT SCALE DRAWING

MATERIAL:

Part #

DEBUR AND BREAK SHARP EDGES

REVISION

DRAWN DATE: 7/13/16

Drawn By: MWR

SCALE:1:1

SHEET 3 OF 3