

ITEM NO.	PART NUMBER	DESCRIPTION	QTY.
1	#243B RM	5" Round Canopy	1
2	MP Plate HB	Monopoint Plate for Half Ball for MP Crossbar 2.82" L x 1.650" W x .075" Material Thickness Half Ball Opening for #35, #34 and #147 Tapped 8/32" Hole Zinc Plated Steel	1
3	MP Swivel Clip	Mono Point Swivel Retaining Clip for MP-Plate HB Spring Steel	1
4	MP Crossbar Round	4.75" Round Crossbar .080" Material Thickness Zinc Plated Steel	1
5	#237	.875" Hole Bushing .945" W x .750" I.D. x .250" H .063" Max Panel Thickness	1
6	MP Screws	6/32" x 3/4" Long Zinc Plated Flat Countersunk Head Machine Screw. Available with White, Black or Zinc Finished Heads	2
7	#77	1/2" IP Locknut Zinc Plated 1.14" O.D. x .125" H	2
8	#147	1/2" IP Tap Half Ball	1
9	#32	8/32 Green Ground Screw	1
10	#183	8/32" x 1/4" Philip Head Ext Sems Steel Zinc Screw	1

**STEM LENGTH WILL VARY. ORDER SEPARATELY
MP SW1/2 RD USED WITH STEM 1/2" IP
1/2" IPS .800"-.810" O.D. 14 T.P.I.**

*45° SWIVEL

This Document Contains Proprietary Data that is property of Pendant Systems which reserves all rights to it. Unauthorized use without authorization is prohibited.

Pendant Systems
1670 Winchester Rd.
Bensalem, PA 19020
P-215-638-8552
F-215-638-8554
www.PendantSystems.com

UNLESS OTHERWISE SPECIFIED DIMENSIONS ARE IN BOTH INCHES & MILLIMETERS UNLESS OTHERWISE NOTED TOLERANCES: LINEAR: XX= .02" XXX= +.010" ANGULAR: ± 1 Degree		FINISH:	TITLE: MP SW 1-2 RD
DO NOT SCALE DRAWING	MATERIAL:	Part #	REVISION
DEBUR AND BREAK SHARP EDGES		SCALE: NTS	SHEET 1 OF 2
DRAWN DATE: 3/7/16	Drawn By: MWR		

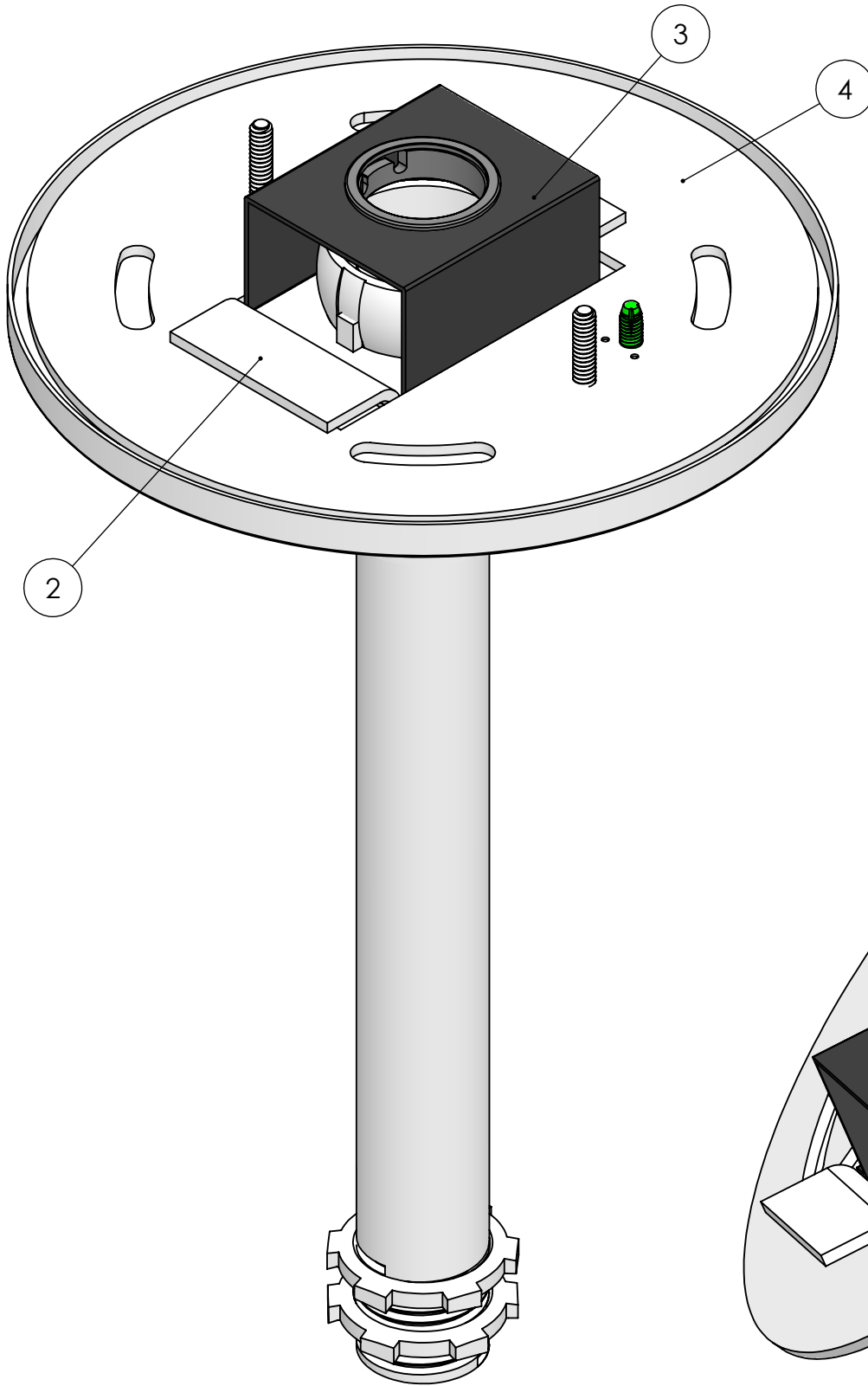

This Document
Contains Proprietary
Data that is property
of Pendant Systems
which reserves all
rights to it.
Unauthorized use
without authorization
is prohibited.

Pendant Systems
1670 Winchester Rd.
Bensalem, PA 19020
P-215-638-8552
F-215-638-8554
www.PendantSystems.com

UNLESS OTHERWISE SPECIFIED DIMENSIONS ARE IN INCHES & MILLIMETERS UNLESS OTHERWISE NOTED TOLERANCES:
LINEAR: XX= .02' XXX= $\pm .010$ " ANGULAR: ± 1 Degree

FINISH:
MATERIAL:

TITLE:
MP SW 1/2 RD ADJ Assembled

DO NOT SCALE DRAWING
DEBUR AND BREAK SHARP EDGES

Part #

SCALE: NTS
SHEET 2 OF 2
REVISION

DRAWN DATE: 3/7/16

Drawn By: MWR

SCALE: NTS
SHEET 2 OF 2
REVISION