

[127.00mm]
 ϕ 5.000in

[21.34mm]
 ϕ .840in

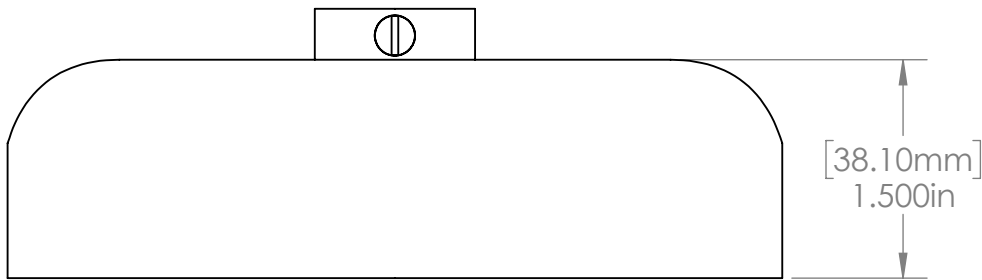
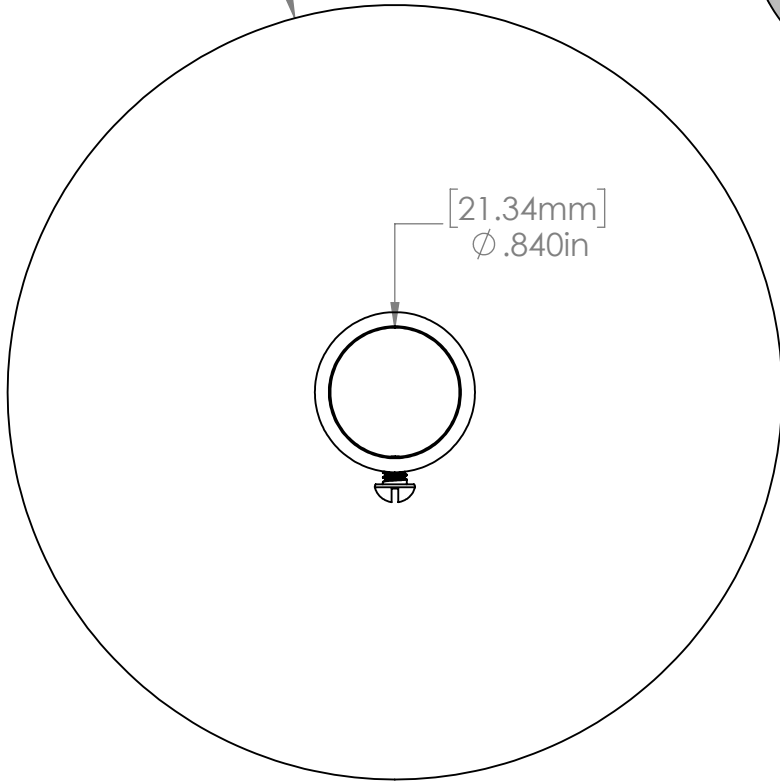

[38.10mm]
 1.500in

Deep Canopy w/ 1/2" IP Slip Ring Inserted
 5" DIA x 1.5" H x .030" Material Thickness
 Zinc Plated
 Add Suffix WHT for White or BK for Black

This Document
 Contains Proprietary
 Data that is property
 of Pendant Systems
 which reserves all
 rights to it.
 Unauthorized use
 without authorization
 is prohibited.

Pendant Systems

1670 Winchester Rd.
 Bensalem, PA 19020
 P-215-638-8552
 F-215-638-8554
www.PendantSystems.com

UNLESS OTHERWISE SPECIFIED DIMENSIONS ARE IN BOTH INCHES & MILLIMETERS UNLESS OTHERWISE NOTED TOLERANCES:

LINEAR: XX= .02" XXX= \pm .010" ANGULAR: \pm 1 Degree

FINISH:

TITLE:

168B

DO NOT SCALE DRAWING

MATERIAL:

Part #

DEBUR AND BREAK SHARP EDGES

REVISION

DRAWN DATE: 7/7/16

Drawn By: MWR

SCALE: NTS

SHEET 1 OF 1